

MAX FLOW 13.2 GPM / 50.0 L.MIN
MAX PRESSURE 2900 PSI / 200 BAR
RATED PUMP SPEED 1450 RPM
POWER REQUIREMENT 26.0 HP GAS
LUBRICATION 34.5 OZ UDOR LUBE

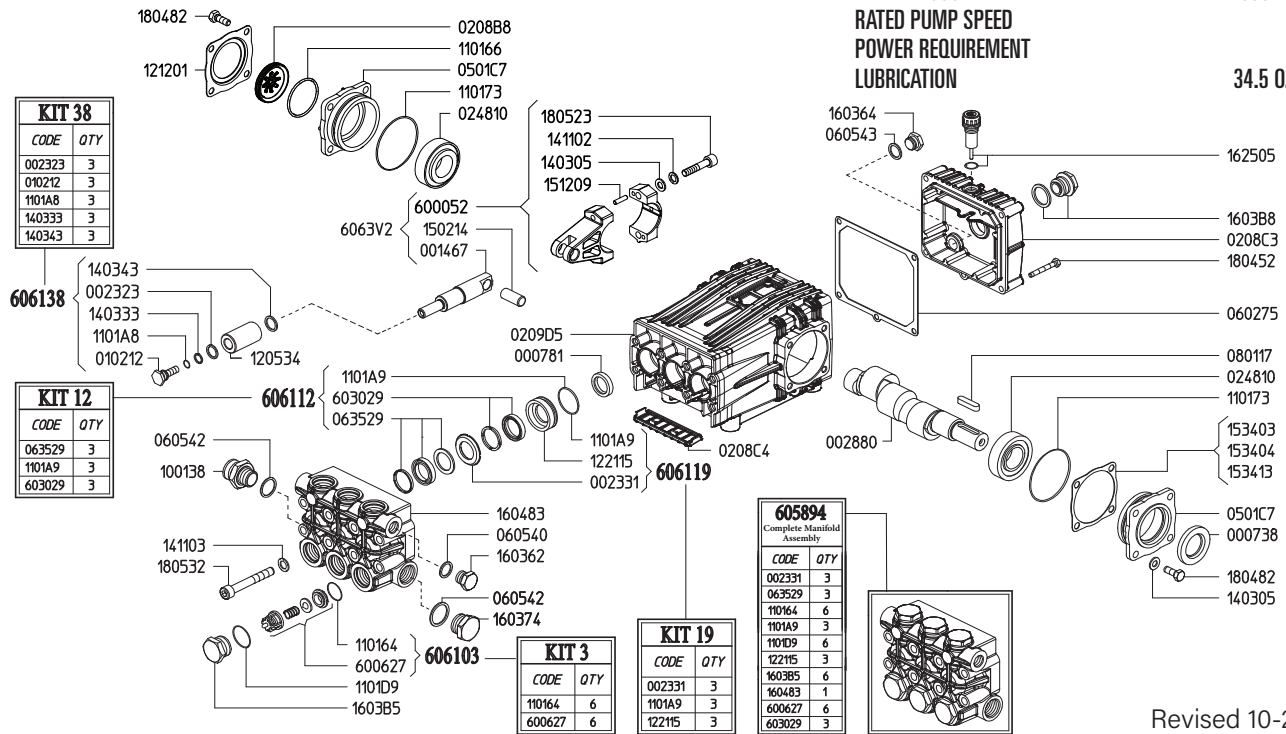

Revised 10-27-2023

Part #	Description	Qty
0007.38	OIL SEAL D30	1
0007.81	OIL SEAL D20	3
0014.67	PLUNGER GUIDE D22/25/28 "C/CK"	3
0023.23	RING D10.4 ^B	3
0023.31	UPPER RING D28 ^{D E}	3
0028.80	MALE SHAFT D24	1
0102.12	PLUNGER BOLT ^B	3
0208.B8	OIL SIGHT GLASS	1
0208.C3	BACK COVER "C/CK"	1
0208.C4	COVER "CK"	1
0209.D5	CRANKCASE "C/CK/CH"	1
0248.10	ROLLER BEARING D30	2
0501.C7	BEARING HOLLOW FLANGE	2
0602.75	BACK COVER GASKET	1
0605.40	GASKET D21.5	1
0605.42	GASKET D27	2
0605.43	GASKET D17	1
0635.29	HIGH PRESSURE SEAL KIT D28 ^{C E}	3
0801.17	KEY A8X7X35	1
1001.38	NIPPLE G3/4M - G1"M	1
1101.64	O-RING - VALVE ^{A E}	6
1101.66	O-RING - OIL SIGHT GLASS	1
1101.73	O-RING - BEARING FLANGE	2
1101.A8	O-RING - PLUNGER BOLT ^B	3
1101.A9	O-RING - PRESSURE RING ^{C D E}	3
1101.D9	O-RING - VALVE PLUG ^E	6
1205.34	CERAMIC PLUNGER D28	3
1212.01	RETAINER - OIL SIGHT GLASS	1
1221.15	PRESSURE RING D28 ^{D E}	3
1403.05	WASHER D8.4	10
1403.33	WASHER D13.4 ^B	3

Part #	Description	Qty
1403.43	WASHER D13.2	3
1411.02	SERATED WASHER D8	6
1411.03	SERATED WASHER D10	8
1502.14	PIN D14X32	3
1512.09	PLUG D5X20 UNI1707	6
1534.03	SHIM 0.1MM	-
1534.04	SHIM 0.2MM	-
1534.13	SHIM 0.05MM	-
1603.62	PLUG G31/2	1
1603.64	PLUG G3/8	1
1603.74	PLUG G3/4	1
1603.B8	OIL PLUG G3/4 + GASKET	1
1603.H7	VALVE PLUG "CK" PISTON D22/25 ^E	6
1604.83	HEAD "CK" D28 ^E	1
1625.05	OIL PLUG G3/8	1
1804.52	HEX BOLT M6X45	5
1804.82	HEX BOLT M8X22	8
1805.23	ALLEN BOLT M8X40	6
1805.32	ALLEN BOLT M10X75	8
6000.52	ROD ASSEMBLY	3
6006.27	VALVE ASSEMBLY W/O O-RING ^{A E}	6
6030.29	LOW PRESSURE SEAL ASSY D28 ^{C E}	3
6058.94	COMPLETE MANIFOLD ASSEMBLY	1
6061.03	KIT 3 VALVE KIT	1
6061.38	KIT 38 PLUNGER KIT	1
6061.12	KIT 12 WATER SEAL KIT D28 "C/CK"	1
6061.19	KIT 19 BRASS RING KIT D28 "C/CK"	1

^A Parts in 6061.03 (Kit 3).
^B Parts in 6061.38 (Kit 38).
^C Parts in 6061.12 (Kit 12).
^D Parts in 6061.19 (Kit 19).
^E Parts in 6058.94 (Complete Manifold Assembly).

**GAS ENGINE GEAR REDUCTION FOR
B/BK/MS/MWT/C/CS/CWT/CK/CX-SERIES PLUNGER PUMPS
on GAS ENGINES with 1" SHAFTS
REQUIRES 9.0 OZ. 90W GEAR LUBE**

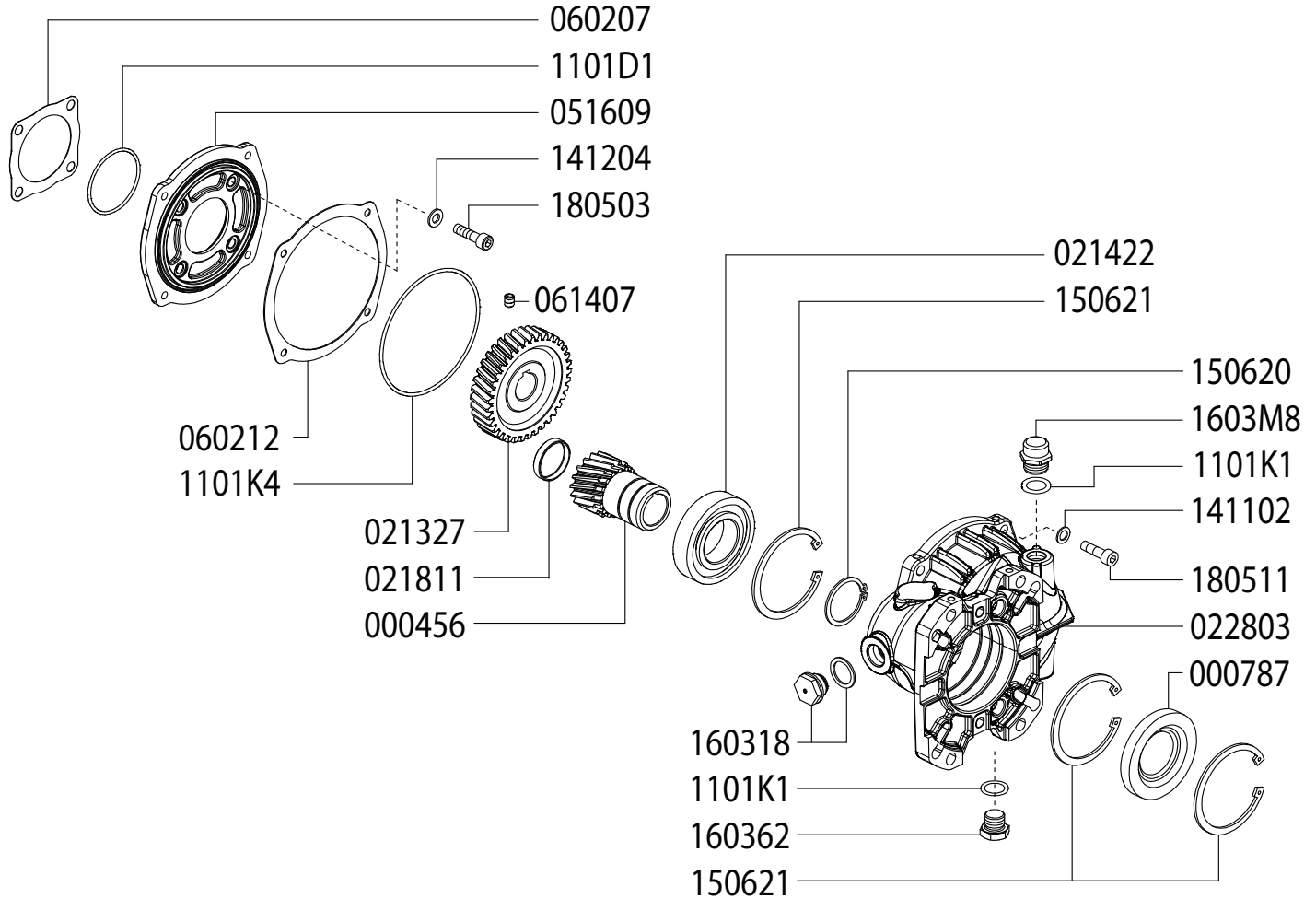

Revised 10-27-2023

Part #	Description	Qty	Part #	Description	Qty
0004.56	GEAR SHAFT "RC122" 1"	1	1101.K4	O-RING - RC122 FLANGE - INSIDE	1
0007.87	SEAL	1	1403.05	WASHER D8,4	4
0213.27	GEAR "RM122" IP	1	1411.02	SERATED WASHER D8	4
0214.22	BALL BEARING D40 "RC122K"	1	1412.04	BONDED WASHER D8.3	4
0218.11	CAP - D37X7	1	1506.20	SNAP RING D40	1
0228.03	COUPLER "RC122"	1	1506.21	SNAP RING D80	3
0516.09	FLANGE "RC122"	1	1603.18	OIL PLUG G1/2 + GASKET	1
0602.07	GASKET "RC122"	1	1603.62	PLUG G1/2	1
0602.12	GASKET "RC122" SPLIT BODY	1	1603.M8	OIL CAP - RC122	1
0614.07	SET SCREW M8X10 UNI5929	1	1805.03	ALLEN SCREW M8X30	4
1101.D1	O-RING - RC122 FLANGE - OUTSIDE	1	1805.11	ALLEN SCREW M8X25	4
1101.K1	O-RING - OIL PLUG / OIL CAP	2			

*Dimensional Drawings are
Shown in Millimeters.
To Convert to Inches,
Multiply Dimension x 0.03937*

CK SERIES PUMPS 10 GPM & OVER

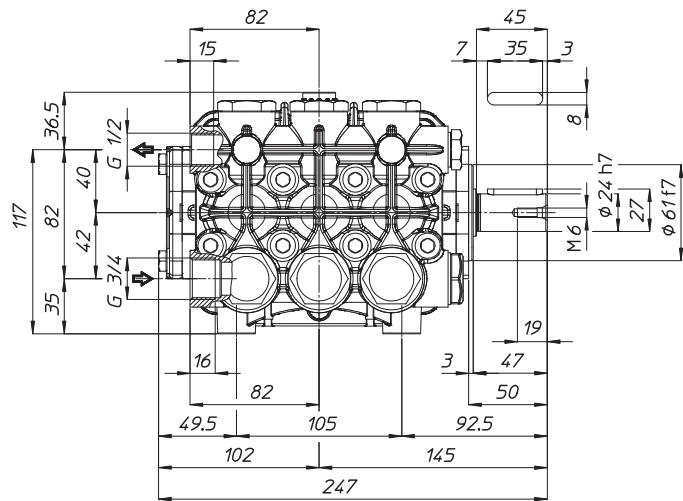
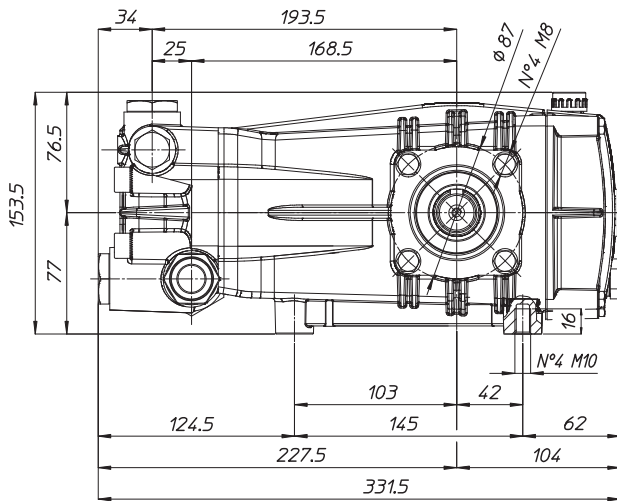

TORQUE SPECS

Ref.	Description	Ft./lb.	Nm	Loctite®
1	Head Bolts	37	50	-
2	Valve Caps	103	140	243
3	Inlet Cap	103	140	-
4	Outlet Cap	103	140	243
5	Bearing Flange Bolts	19	25	-
6	Rear Cover Bolts	8	11	-
7	Connecting Rod Bolts	19	25	270
8	Plunger Bolts	15	20	270
9	Valve Cover Bolts	-	-	-
10	Oil Drain Plug	8	11	-

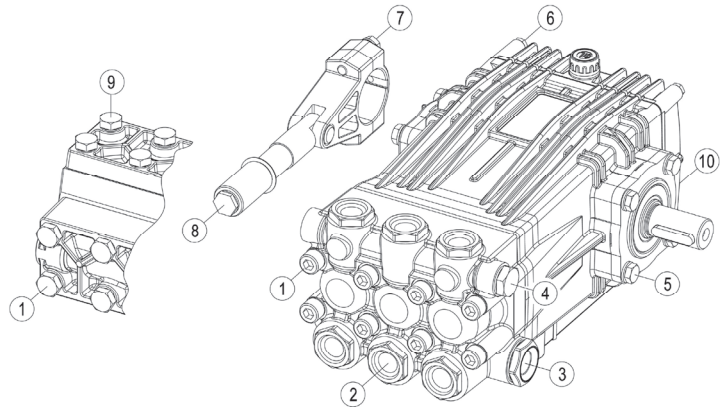

PARTS BREAKDOWN FOR MODEL FH-12.5/500
RICE HYDRO, INC.

PART NUMBER..	DESCRIPTION..	QTY REQ'D
UD04-0007.38	OIL SEAL	1
UD04-0007.81	OIL SEAL	3
UD04-0014.67	PLUNGER GUIDE	3
UD04-0023.23	SUPPORT RING	3
UD04-0023.31	UPPER RING	3
UD04-0028.80	MALE SHAFT	1
UD04-0102.12	PLUNGER BOLT	3
UD04-0208.B8	OIL SIGHT GLASS	1
UD04-0208.C3	BACK COVER	1
UD04-0208.C4	COVER	1
UD04-0209.D5	CRANKCASE	1
UD04-0248.10	ROLLER BEARING	2
UD04-0501.C7	BEARING HOLLOW FLANGE	2
UD04-0602.75	BACK COVER GASKET	1
UD04-0605.40	GASKET	1
UD04-0605.42	GASKET	2
UD04-0605.43	GASKET	1
UD04-0635.29	HIGH PRESSURE SEAL KIT	3
UD04-0801.17	KEY	1
UD04-1001.38	NIPPLE	1
UD04-1101.64	O-RING - VALVE	6
UD04-1101.66	O-RING - OIL SIGHT GLASS	1
UD04-1101.73	O-RING - BEARING FLANGE	2
UD04-1101.A8	O-RING - PLUNGER BOLT	3
UD04-1101.A9	O-RING - PRESSURE RING	3
UD04-1101.D9	O-RING - VALVE PLUG	6
UD04-1205.34	CERAMIC PLUNGER	3
UD04-1212.01	RETAINER - OIL SIGHT GLASS	1
UD04-1221.15	PRESSURE RING	3
UD04-1403.05	WASHER	10
UD04-1403.33	WASHER	3
UD04-1403.43	WASHER	3
UD04-1411.02	SERATED WASHER	6
UD04-1411.03	SERATED WASHER	8
UD04-1502.14	PIN	3
UD04-1512.09	PLUG	6
UD04-1534.03	SHIM 0.1MM	
UD04-1534.04	SHIM 0.2MM	
UD04-1534.13	SHIM 0.05MM	
UD04-1603.62	PLUG	1
UD04-1603.64	PLUG	1
UD04-1603.74	PLUG	1
UD04-1603.B8	OIL PLUG	1
UD04-1603.H7	VALVE PLUG	6
UD04-1604.83	HEAD	1
UD04-1625.05	OIL PLUG	1
UD04-1804.52	HEX BOLT	5
UD04-1804.82	HEX BOLT	8
UD04-1805.23	ALLEN BOLT	6
UD04-1805.32	ALLEN BOLT	8
UD04-6000.52	ROD ASSEMBLY	3
UD04-6006.27	VALVE ASSY W/O O-RING	6
UD04-6030.29	LOW PRESSURE SEAL KIT	3
UD04-6058.94	COMPLETE MANIFOLD ASSY	1

PARTS BREAKDOWN FOR MODEL FH-12.5/500
RICE HYDRO, INC.

PART NUMBER..	DESCRIPTION..	QTY REQ'D
GEAR REDUCTION..		
UD04-0004.56	1" GEAR SHAFT	1
UD04-0007.87	SEAL	1
UD04-0213.27	GEAR	1
UD04-0214.22	BALL BEARING	1
UD04-0218.11	CAP	1
UD04-0228.03	COUPLER	1
UD04-0516.09	FLANGE	1
UD04-0602.07	GASKET	1
UD04-0602.12	GASKET	1
UD04-0614.07	SET SCREW	1
UD04-1101.D1	O-RING - FLANGE - OUTSIDE	1
UD04-1101.K1	O-RING - OIL PLUG / OIL CAP	2
UD04-1101.K4	O-RING - FLANGE - INSIDE	1
UD04-1403.05	WASHER	4
UD04-1411.02	SERATED WASHER	4
UD04-1412.04	BONDED WASHER	4
UD04-1506.20	SNAP RING	1
UD04-1506.21	SNAP RING	3
UD04-1603.18	OIL PLUG + GASKET	1
UD04-1603.62	PLUG	1
UD04-1603.M8	OIL CAP	1
UD04-1805.03	ALLEN SCREW M8x30	4
UD04-1805.11	ALLEN SCREW M8x25	4
MISCELLANOUS PARTS..		
PUMP-12.5/500	TRIPLEX PLUNGER PUMP	1
HONDA-GX270UTQA2	270 CC 9 HP HONDA GEAR REDUCTION	1
CHECKVALVE-1/2CON	1/2" FEMALE CHECKVALVE	1
BALLVALVE-1/2	1/2" BALLVALVE	1
BALLVALVE-S-1&1/2	STAINLESS STEEL BALLVALVE	5
SPRAY-6815-700-1/2	PRESSURE REGULATOR	1
ADAPTER-NST-1&1/2	1&1/2" NPT X NST OUTLET ADAPTER	4
SWIVEL-INLET-FH3	2&1/2" FEMALE SWIVEL INLET	1
CASTER-SWIVEL-6	6" SWIVEL CASTER	4
GAUGE-600	0-600 PSI LIQUID FILLED GAUGE	1
LABEL-KIT-FH	INSTRUCTION AND CAUTION STICKERS	1
KITS..		
	*Kits are all inclusive	
UD04-6061.03	VALVE KIT (KIT 3)	1
UD04-6061.12	WATER SEAL KIT (KIT 12)	1
UD04-6061.19	BRASS RING KIT (KIT 19)	1
UD04-6061.38	PLUNGER KIT (KIT 38)	1