

Maximum Flow	61.0 GPM / 238 lpm
Maximum Pressure	300 PSI / 20 bar
Maximum RPM	540
Inlet Port - Hose Barb	2" HB
Outlet Port - Hose Barb	1-1/2" HB
Bypass - Hose Barb	-
Dimensions	14.5"L x 15.5"W x 18.5"H
Weight	80 lbs

**Lubrication:** Requires 90 oz. of Udor Lube 40W Premium Pump Oil.  
 Alternate Oil: 30W non-detergent or 15W-40 non-detergent oil.

8700.44CK		606228		6062D3		6062H4	
▲		●		■		◆	
CODE	QTY	CODE	QTY	CODE	QTY	CODE	QTY
010201	6	010201	6	110101	12	090361	6
030107	6	030107	6	600677	12	110101	12
090361	6						
110101	12						
110142	1						
110193	2						
600677	12						

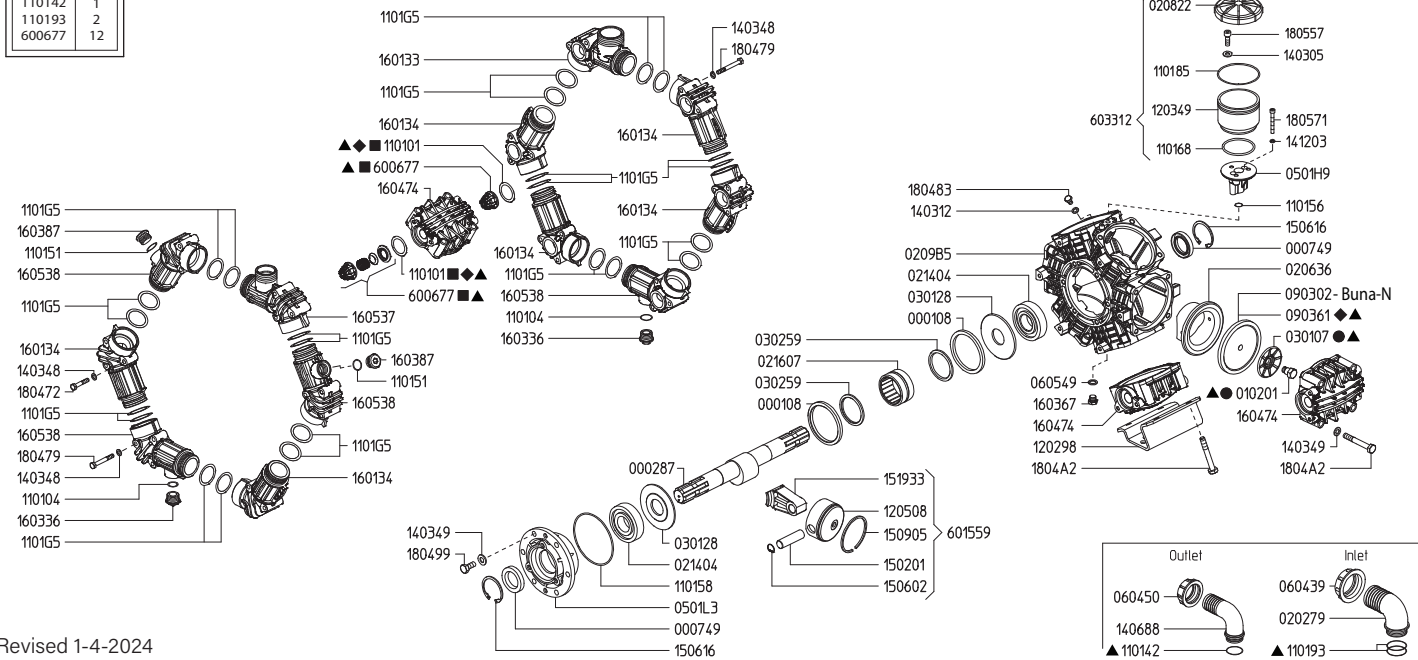

Revised 1-4-2024

Part #	Description	Qty
0001.08	RETAINER RING	1
0002.87	CRANKSHAFT TS 2C	1
0007.49	OIL SEAL D35	2
0102.01	DIAPHRAGM BOLT ●▲	6
0202.79	INLET HOSE BARB D50	1
0206.36	SLEEVE D75	6
0208.22	OIL RESERVOIR CAP	1
0209.B5	CRANKCASE	1
0214.04	BALL BEARING D35	2
0216.07	ROLLER BEARING D55	1
0301.07	DIAPHRAGM WASHER ●▲	6
0301.28	ROD DISC	2
0302.59	BEARING DISC	2
0501.H9	OIL CUP SUPPORT FLANGE	1
0501.L3	BEARING FLANGE	1
0604.39	BARB NUT G2"	1
0604.50	BARB NUT G1-1/2"	1
0605.49	GASKET D13	1
0903.02	PISTON DIAPHRAGM - BUNA-N 116MM	6
0903.61	PISTON DIAPHRAGM - GREENTECH 116MM ◆▲	6
1101.01	O-RING - VALVE ◆◆▲	12
1101.04	O-RING - DRAIN PLUG	2
1101.42	O-RING - DISCHARGE BARB▲	1
1101.51	O-RING - PLUG	2
1101.56	O-RING - OIL RESERVIOR	1
1101.58	O-RING - BEARING FLANGE	1
1101.68	O-RING - OIL RESERVIOR	1
1101.85	O-RING - OIL RESERVIOR	1
1101.93	O-RING - INLET BARB▲	2
1101.G5	O-RING - MANIFOLD TUBE	24
1202.98	BASE PLATE "ZETA 230/260/300"	2
1203.49	OIL RESERVOIR	1
1205.08	ALUMINIUM PISTON D75	6
1403.05	WASHER M8	3
1403.12	GASKET D8.5	1

Part #	Description	Qty
1403.48	WASHER M8	36
1403.49	WASHER M10	26
1406.88	OUTLET HOSE BARB D38	1
1412.03	BONDED WASHER M6	2
1502.01	PIN D18X64	6
1506.02	SNAP RING D18	6
1506.16	SNAP RING D55	2
1509.05	PISTON RING D75	6
1519.33	CONNECTING ROD	6
1601.33	SUCTION MANIFOLD G2" M	1
1601.34	INLET-OUTLET MANIFOLD	6
1603.36	PLUG G3/4	2
1603.67	PLUG G1/4	1
1603.87	PLUG G3/4	2
1604.74	HEAD	6
1605.37	OUTLET MANIFOLD G1"1/2 M	1
1605.38	INLET-OUTLET MANIFOLD G3/4 F	4
1804.72	HEX BOLT M8X50	12
1804.79	HEX BOLT M8X70	24
1804.83	HEX BOLT M8X12	1
1804.99	HEX BOLT M10X25	6
1804.A2	HEX BOLT M10X75	24
1805.57	ALLEN BOLT M8X22	3
1805.71	ALLEN BOLT M6X50	2
6006.77	VALVE ASSEMBLY W/O O-RING ■▲	12
6015.59	ROD ASSEMBLY - D75 PISTON	6
6033.12	OIL RESERVOIR ASSEMBLY	1
6062.28	DIAPHRAGM BOLT & WASHER (KIT 527)	1
6062.D3	IN/OUTLET VALVE KIT "ZETA 300" (KIT 636)	1
6062.H4	DIAPHTAGM KIT - GREENTECH (KIT 672)	1
8700.44CK	COMPLETE REPAIR KIT	1

- Parts in 6062.28 (Kit 527)
- Parts in 6062.D3 (Kit 636)
- ◆ Parts in 6062.H4 (Kit 672)
- ▲ Parts in Kit 8700.44CK



# ZETA 230/260 DIMENSIONS

All Dimensions are WITHOUT Control Unit or Regulator

Dimensional Drawings are Shown in Millimeters. To Convert to Inches, Multiply Dimension x 0.03937

Specifications	ZETA 230	ZETA 260
Inlet Port - Hose Barb	2" HB	2" HB
Outlet Ports - Hose Barb	1-1/2" HB	1-1/2" HB
Dimensions - Pump Only	14.5"L x 15.5"W x 18.5"H	
Diaphragm Material	GREENTECH (Std) Buna-N (Opt)	

**Lubrication:** Requires 39 oz. of Udor Lube 40W Premium Pump Oil. Alternate Oil: 30W non-detergent or 15W-40 non-detergent oil.

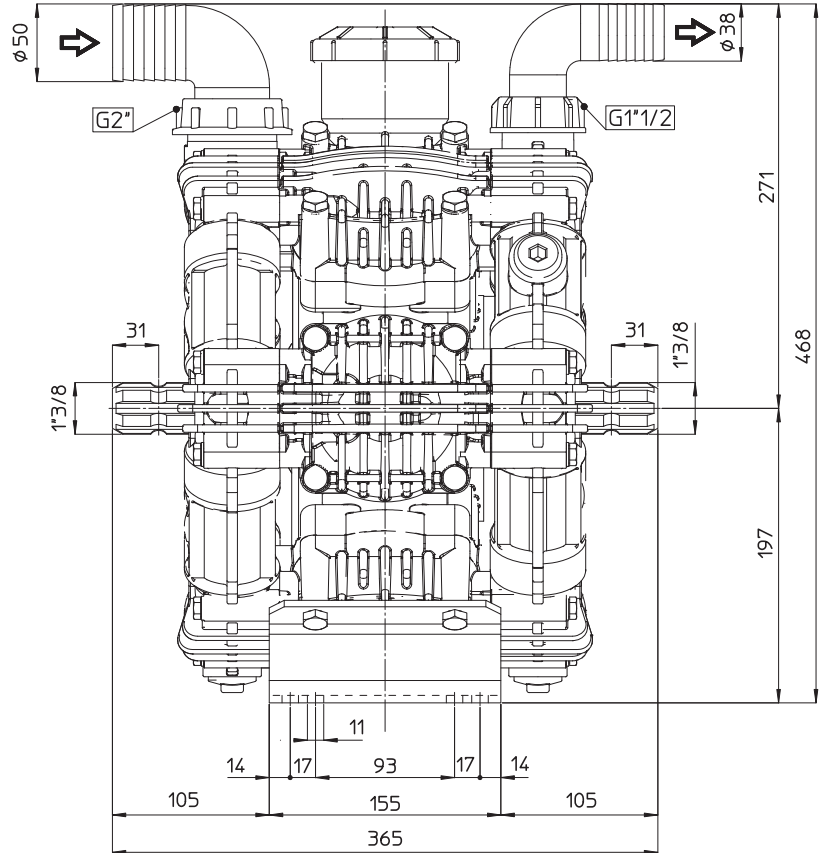
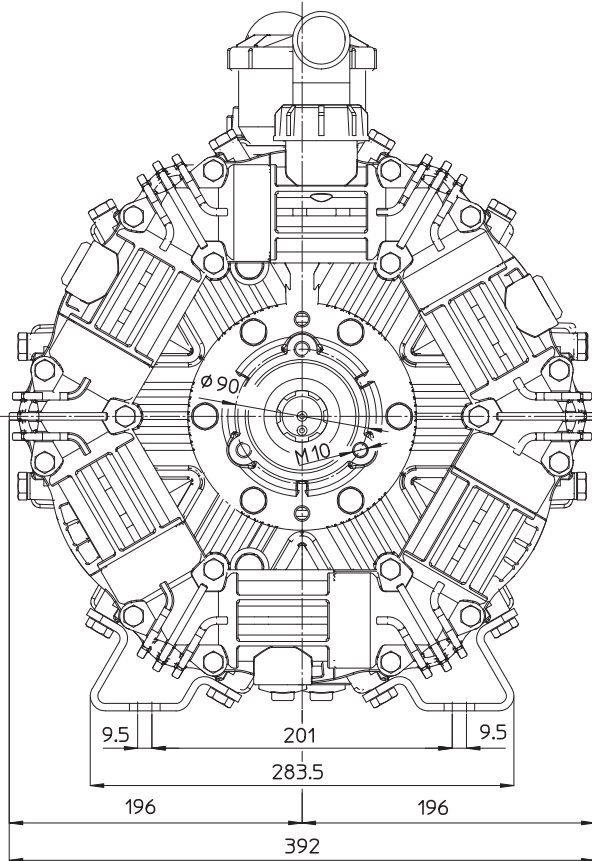

## TORQUE SPECS

Ref.	Description	Ft./lb.	Nm
1	Diaphragm Bolts (Use Loctite 243)	22	30
2	Head Bolts	30	40
3	Pulsation Dampener Bolts	18	25
4	Oil Cup Bolts	6	8
5	Manifold Bolts (Plastic)	14	20
NS	Bearing Flange Bolts (not shown)	25	34

