

MAX FLOW  
MAX PRESSURE  
RATED PUMP SPEED  
POWER REQUIREMENT  
LUBRICATION

3.0 GPM / 11 L/MIN  
2000 PSI / 130 BAR  
3400 RPM  
5.5 HP GAS ENGINE  
14 OZ UDOR LUBE

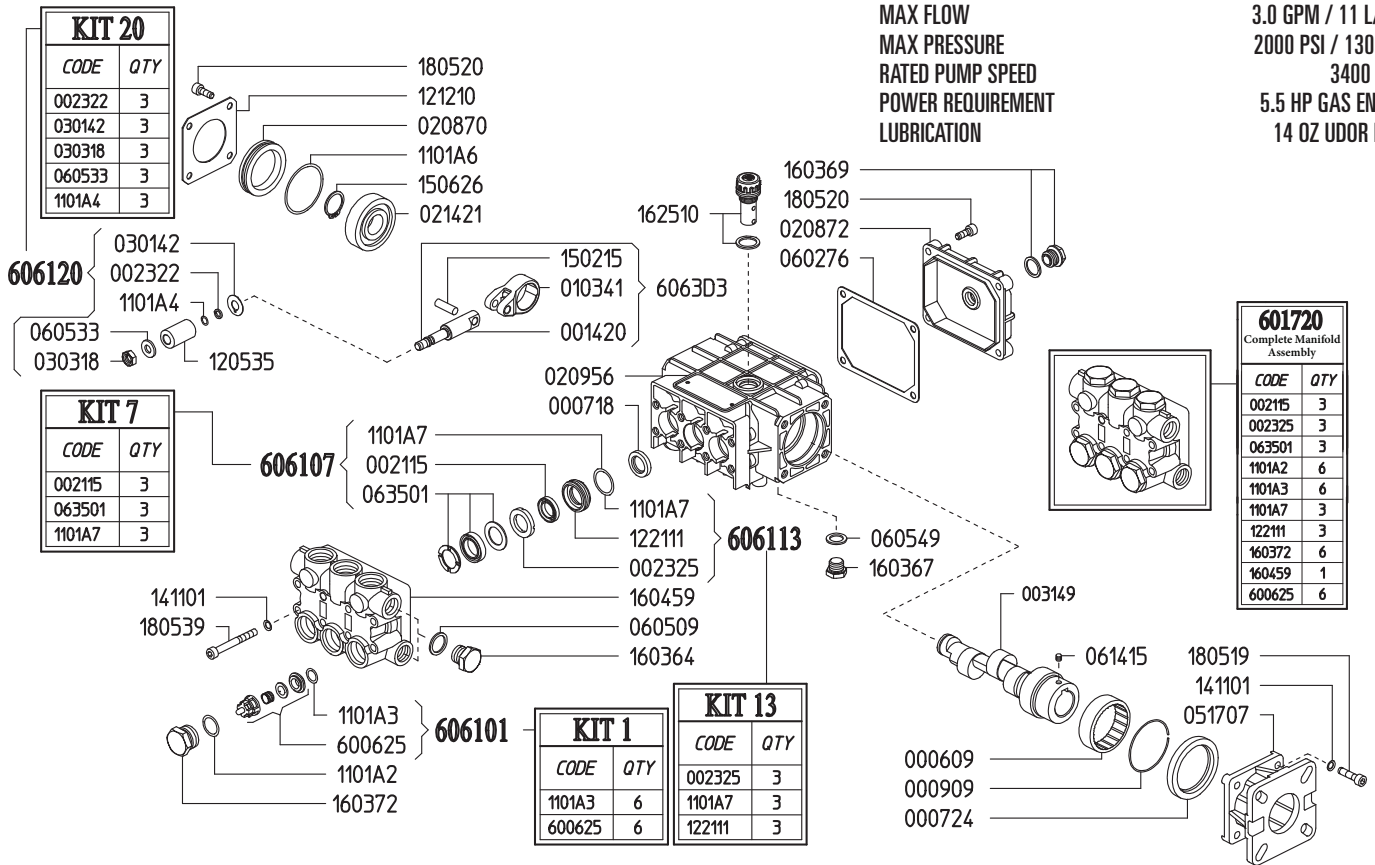

Part #	Description	Qty	Part #	Description	Qty
0006.09	BUSHING D45X52X16 HK45-16	1	1101.A7	O-RING - LP SEAL RETAINER <sup>BCE</sup>	3
0007.18	OIL SEAL D15X24X4	3	1205.35	CERAMIC PLUNGER D15X30 "PN"	3
0007.24	OIL SEAL D40X52X7	1	1212.10	METAL COVER "PN"	1
0009.09	ELASTIC RING D52X2.5	1	1221.11	LOW PRESS. SEAL RETAINER D15 <sup>CE</sup>	3
0014.20	PLUNGER GUIDE D15/18 "PN"	3	1411.01	SERATED WASHER D6	12
0021.15	WATER SEAL LP. D15 <sup>B</sup>	3	1502.15	PIN D7X25.5	3
0023.22	RING D6.3X9X1.3 2021 "PN/C/G" <sup>CE</sup>	3	1506.26	SNAP RING D20	1
0023.25	INTERMEDIATE RING D15 "PN"	3	1603.64	PLUG G3/8	1
0031.49	HOLLOW SHAFT "PN" D3/4"	1	1603.67	PLUG G1/4	1
0103.41	CONNECTING ROD "PN/PS"	3	1603.69	OIL PLUG G1/4+GASKET	1
0208.70	COVER "PN"	1	1603.72	VALVE PLUG "PN" PISTON D15/18 <sup>E</sup>	6
0208.72	BACK COVER "PN"	1	1604.59	HEAD "PN" PISTON D15/18 <sup>E</sup>	1
0209.56	CRANKCASE "PN/PS"	1	1625.10	OIL PLUG G3/8 "PN"	1
0214.21	BALL BEARING D20X52X15	1	1805.19	ALLEN BOLT M6X25	4
0301.42	SLINGER RING "PN/PK/PKWT/PS" <sup>D</sup>	3	1805.20	ALLEN BOLT M6X16	8
0303.18	NUT "PN/PK/PKWT/PS M8XH5" <sup>D</sup>	3	1805.39	ALLEN BOLT M6X60	8
0517.07	ENGINE FLANGE "PN" HP2/5	1	6006.25	VALVE ASSY "PN" W/O O-RING <sup>AE</sup>	6
0602.76	BACK COVER GASKET "PN/PK/PW/PS"	1	6017.20	COMPLETE MANIFOLD ASSEMBLY	1
0605.09	GASKET D17X23X1.5 (G3/8)	1	6061.01	KIT 1 - VALVE KIT "PN/PW"	1
0605.33	GASKET D8X14X2 <sup>D</sup>	3	6061.07	KIT 7 - WATER SEAL KIT D15 "PN/PK"	1
0605.49	GASKET D13X19X1.5	1	6061.13	KIT 13 - BRASS RING KIT D15 "PN"	1
0614.15	SET SCREW M8X8	1	6061.20	Kit 20 - PLUNGER KIT D15/18 "PN"	1
0635.01	HIGH PRESS. SEAL ASSY D15 <sup>B</sup>	3			
1101.A2	O-RING - VALVE CAP <sup>E</sup>	6			
1101.A3	O-RING - VALVE <sup>AE</sup>	6			
1101.A4	O-RING - PLUNGER <sup>D</sup>	3			
1101.A6	O-RING - BEARING COVER	1			

A Parts in 6061.01 (Kit 1).  
 B Parts in 6061.07 (Kit 7).  
 C Parts in 6061.13 (Kit 13).  
 D Parts in 6061.20 (Kit 20).  
 E Parts in 6017.20 (Complete Manifold Assembly).

*Dimensional Drawings are  
Shown in Millimeters.  
To Convert to Inches,  
Multiply Dimension x 0.03937*

## PN SERIES PUMPS - 3/4" HOLLOW SHAFT w/ GAS ENGINE FLANGE

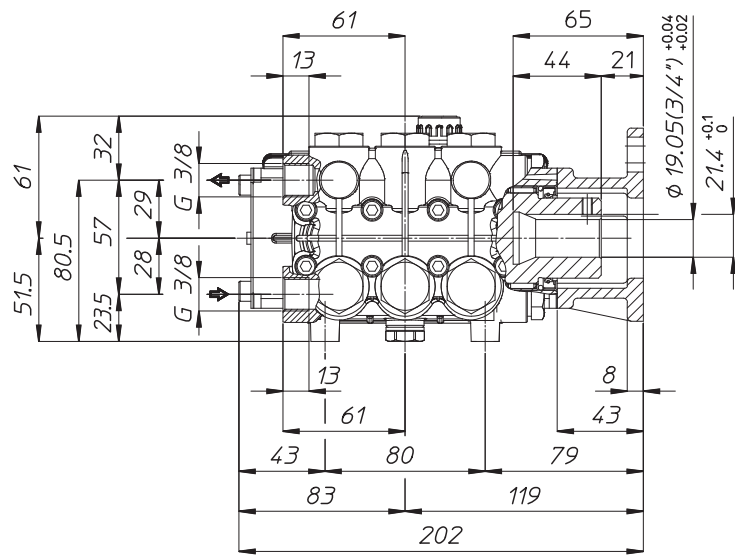
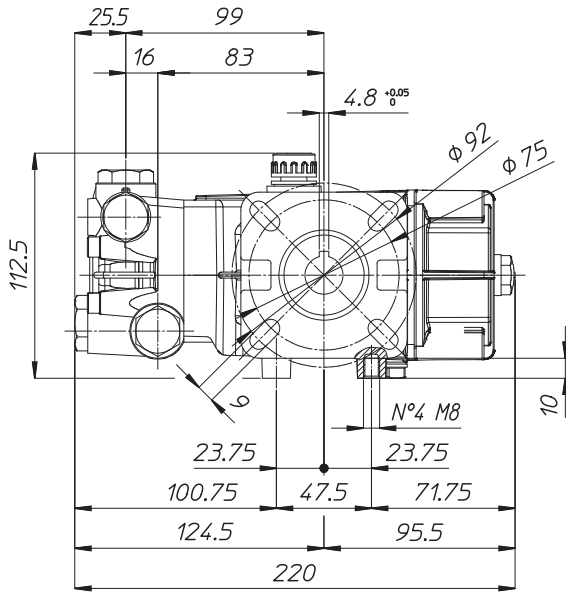

## TORQUE SPECS

Ref.	Description	Ft./lb.	Nm	Loctite®
1	Head Bolts	8	11	-
2	Valve Caps	75	100	243
3	Inlet Cap	60	80	-
4	Outlet Cap	60	80	243
5	Bearing Flange Bolts	8	11	-
6	Rear Cover Bolts	8	11	-
7	Connecting Rod Bolts	-	-	-
8	Plunger Bolts	11	15	270
9	Valve Cover Bolts	-	-	-
10	Oil Drain Plug	6	8	-

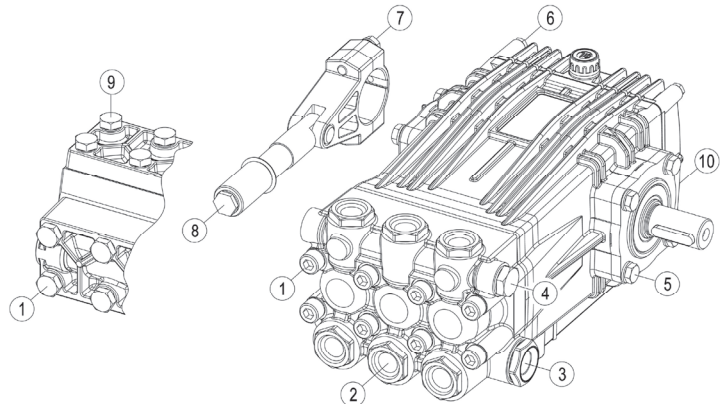

## PARTS BREAKDOWN FOR MODEL TRH-2

RICE HYDRO, INC.

PART NUMBER..	DESCRIPTION..	QTY REQ'D
UD04-0006.09	BEARING	1
UD04-0007.18	SEAL	3
UD02-0007.24	SEAL	1
UD04-0009.09	RETAINER CLIP	1
UD04-0014.20	PLUNGER ROD P SERIES	3
UD04-0021.15	WATER SEAL	3
UD04-0023.22	SUPPORT RING	1
UD04-0023.25	INTERMEDIATE RING	3
UD04-0031.49	HOLLOW SHAFT	1
UD04-0103.41	CONNECTING ROD P SERIES	3
UD04-0208.70	BEARING COVER	1
UD04-0208.72	BACK COVER P SERIES	1
UD04-0209.56	CRANKCASE P SERIES	1
UD04-0214.21	BEARING	1
UD04-0301.42	SLINGER RING	1
UD04-0303.18	PLUNGER NUT	1
UD04-0517.07	FLANGE P SERIES GAS	1
UD04-0602.76	GASKET	1
UD02-0605.09	GASKET	2
UD04-0605.33	PLUNGER WASHER	1
UD04-0605.49	WASHER	1
UD04-0614.15	SET SCREW	1
UD04-0635.01	HIGH PRESSURE SEAL ASSY.	3
UD04-1101.A2	O-RING	6
UD04-1101.A3	VALVE O-RING	6
UD04-1101.A4	O-RING	1
UD04-1101.A6	O-RING	1
UD04-1101.A7	O-RING	1
UD04-1205.35	PLUNGER 15MM	3
UD04-1212.10	END PLATE	1
UD04-1221.11	LOW PRESSURE SEAL RETAINER	3
UD04-1411.01	WASHER P - PUMP	8
UD04-1502.15	CONNECTING ROD PIN	3
UD04-1506.26	SNAP RING	1
UD04-1603.64	DISCHARGE PLUG 3/8	2
UD02-1603.67	DRAIN PLUG	1
UD04-1603.69	SIGHT GLASS	1
UD04-1603.72	VALVE CAP P SERIES	6
UD04-1604.59	MANIFOLD P SERIES 15MM	1
UD04-1625.10	OIL PLUG / VENT CAP	1
UD04-1805.19	BOLT	4
UD04-1805.20	BOLT	8
UD04-1805.39	BOLT	8
UD04-6006.25	VALVE ASSY w/o O-RING	6

## MISCELLANEOUS PARTS..

HONDA-GX200UT2-QX2	196 CC FLANGE MOUNT HONDA	1
MUFFLER-CAP-GX200	HONDA MUFFLER CAP	1
SPEC-PNL3.0/20-T	TRIPLEX PLUNGER PUMP	1
GAUGE-3000	LIQUID FILLED GAUGE	1
BALLVALVE-3/8HP	OUTLET BALLVALVE	1
NEEDLEVALVE-1/4	BLEED VALVE	1
HOSESWIVEL-1/2	SWIVEL HOSE INLET	1
LINESTRAINER-1/2	INLET LINE STRAINER	1
KING-LARGE	LARGE SHIPPING BOX	1
LABEL-KIT-TR	INSTRUCTION AND CAUTION STICKERS	1

\*\* Prior to s/n #45985 \*\*

UNLOADER-500/4000PSI	PRESSURE REGULATOR	1
----------------------	--------------------	---

\*\* After s/n #45985 \*\*

VALVE-RELIEF-2000PSI	PRESSURE REGULATOR	1
----------------------	--------------------	---

PARTS BREAKDOWN FOR MODEL TRH-2  
RICE HYDRO, INC.

OUTLET HOSE..

HOSE-3/8X8-RH	8' FOOT OUTLET HOSE - STANDARD	1
<i>*3/8" Male Rigid Fitting &amp; 3/8" Male Swivel Fitting included on 8ft outlet hose</i>		
COUPLERBODY-BR-3/8F	FEMALE PUMP OUTLET - HOSE	1
COUPLERPLUG-3/8M	MALE PUMP OUTLET - PIPING	1
HOSE-3/8-3000XFT	SPECIFY LENGTH OF HOSE	
3/8" Male Rigid Fitting & 3/8" Male Swivel Fitting		1

KITS:

UD04-6061.01	VALVE KIT	1
UD04-6061.07	SEAL KIT	1
UD04-6061.13	BRASS KIT	1
UD04-6061.20	PLUNGER O-RING KIT	1