

PARTS BREAKDOWN FOR MODEL ST-312/ST-312-B
RICE HYDRO, INC.

PART NUMBER..	DESCRIPTION..	QTY REQ'D
UD04-0006.09	BEARING	1
UD04-0007.18	SEAL	3
UD02-0007.24	SEAL	1
UD04-0009.09	RETAINER CLIP	1
UD04-0014.20	PLUNGER ROD P SERIES	3
UD04-0021.15	WATER SEAL	3
UD04-0023.22	SUPPORT RING	1
UD04-0023.25	INTERMEDIATE RING	3
UD04-0031.49	HOLLOW SHAFT	1
UD04-0103.41	CONNECTING ROD P SERIES	3
UD04-0208.70	BEARING COVER	1
UD04-0208.72	BACK COVER P SERIES	1
UD04-0209.56	CRANKCASE P SERIES	1
UD04-0214.21	BEARING	1
UD04-0301.42	SLINGER RING	1
UD04-0303.18	PLUNGER NUT	1
UD04-0517.07	FLANGE P SERIES GAS	1
UD04-0602.76	GASKET	1
UD02-0605.09	GASKET	2
UD04-0605.33	PLUNGER WASHER	1
UD04-0605.49	WASHER	1
UD04-0614.15	SET SCREW	1
UD04-0635.01	HIGH PRESSURE SEAL ASSY.	3
UD04-1101.A2	O-RING	6
UD04-1101.A3	VALVE O-RING	6
UD04-1101.A4	O-RING	1
UD04-1101.A6	O-RING	1
UD04-1101.A7	O-RING	1
UD04-1205.35	PLUNGER 15MM	3
UD04-1212.10	END PLATE	1
UD04-1221.11	LOW PRESSURE SEAL RETAINER	3
UD04-1411.01	WASHER P - PUMP	8
UD04-1502.15	CONNECTING ROD PIN	3
UD04-1506.26	SNAP RING	1
UD04-1603.64	DISCHARGE PLUG 3/8	2
UD02-1603.67	DRAIN PLUG	1
UD04-1603.69	SIGHT GLASS	1
UD04-1603.72	VALVE CAP P SERIES	6
UD04-1604.59	MANIFOLD P SERIES 15MM	1
UD04-1625.10	OIL PLUG / VENT CAP	1
UD04-1805.19	BOLT	4
UD04-1805.20	BOLT	8
UD04-1805.39	BOLT	8
UD04-6006.25	VALVE ASSY w/o O-RING	6

KITS.. ****KITS ARE ALL INCLUSIVE****

UD04-6061.01	VALVE KIT	1
UD04.6061.07	SEAL KIT	1
UD04.6061.13	BRASS KIT	1
UD04.6061.20	PLUNGER O-RING KIT	1

PARTS BREAKDOWN FOR MODEL ST-312/ST-312-B
RICE HYDRO, INC.

PART NUMBER..	DESCRIPTION..	QTY REQ'D
MISC PARTS..		
HONDA-GX200UT2-QX2	196 CC FLANGE MOUNT HONDA ENGINE	1
BRIGG-130G32-0022-F1	206 CC FLANGE MOUNT BRIGGS ENGINE	1
SPEC-PNL3.0/20-T	TRIPLEX PLUNGER PUMP	1
VALVE-RELIEF-2000PSI	200-2000 PSI PRESSURE REGULATOR	1
GAUGE-2000	0-2000 PSI GAUGE	1
BALLVALVE-3/4	3/4" BALLVALVE	1
BALLVALVE-3/8HP	3/8" HIGH PRESSURE BALLVALVE	1
CHECKVALVE-1/2M	1/2" MXM INLINE CHECKVALVE	1
LINESTRAINER-3/4-80	80 MESH LINESTRAINER ASSEMBLY	1
HYD-VALVE-SHORE	HYDRAULIC VALVE	1
TANK-B200-LD	TANK FOR SHORING UNIT	1
TANK-CAP-ASSY	LID, FLANGE, SCREWS & CHAIN	1
QC-BODY-1/4-2WAY	QUICK CONNECT ENDS OF HOSE	2
QC-PLUG-1/4-2WAY	QUICK CONNECT ON UNIT	1
HOSE-1/4X50-FHWA	1/4" 50 FOOT OUTLET HOSE	1
WHEEL	NO FLAT TIRES	4
LABEL-KIT-ST312	INSTRUCTION AND CAUTION STICKERS	1

MAX FLOW
MAX PRESSURE
RATED PUMP SPEED
POWER REQUIREMENT
LUBRICATION

3.0 GPM / 11 L/MIN
2000 PSI / 130 BAR
3400 RPM
5.5 HP GAS ENGINE
14 OZ UDOR LUBE

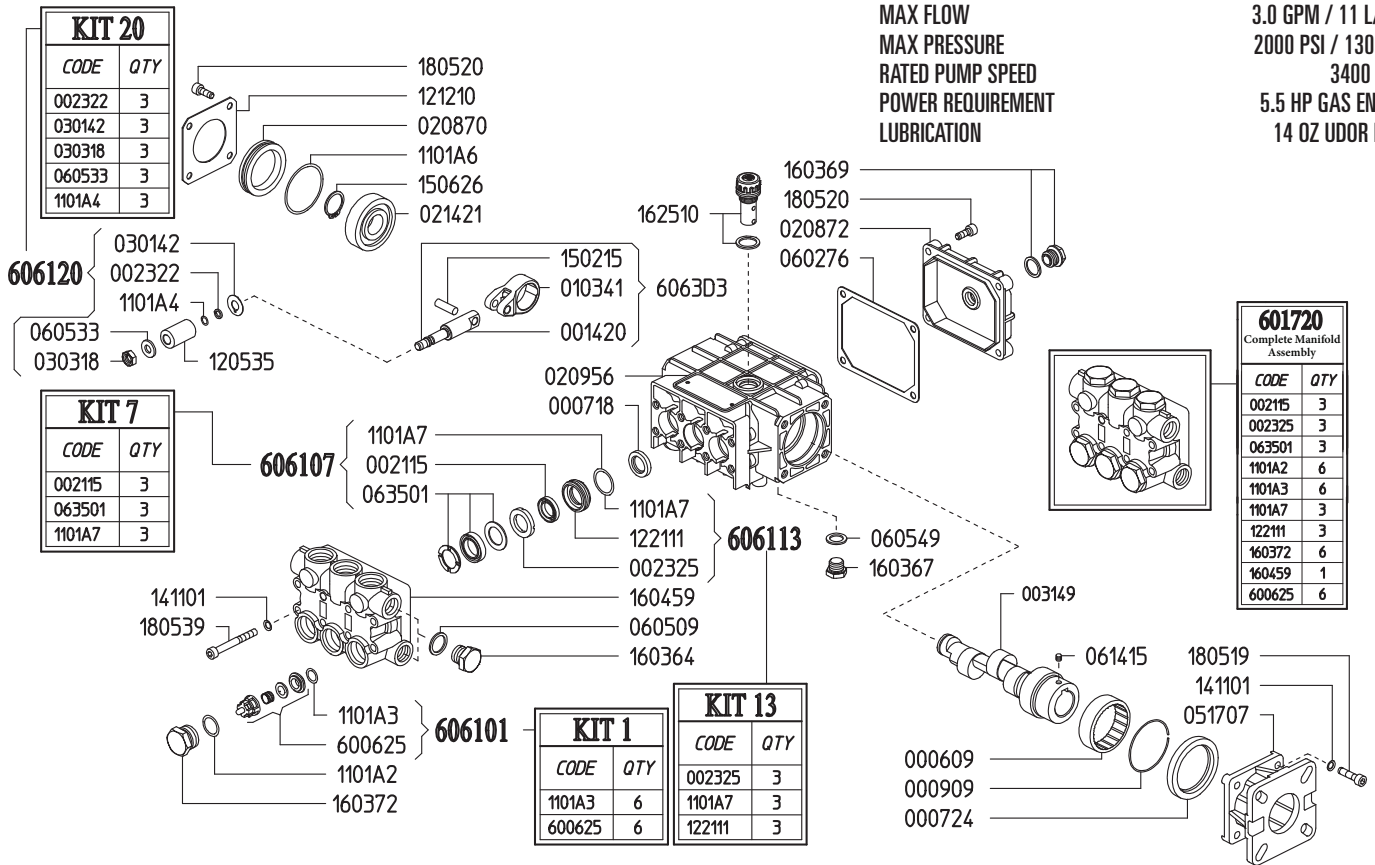

Part #	Description	Qty	Part #	Description	Qty
0006.09	BUSHING D45X52X16 HK45-16	1	1101.A7	O-RING - LP SEAL RETAINER ^{BCE}	3
0007.18	OIL SEAL D15X24X4	3	1205.35	CERAMIC PLUNGER D15X30 "PN"	3
0007.24	OIL SEAL D40X52X7	1	1212.10	METAL COVER "PN"	1
0009.09	ELASTIC RING D52X2.5	1	1221.11	LOW PRESS. SEAL RETAINER D15 ^{CE}	3
0014.20	PLUNGER GUIDE D15/18 "PN"	3	1411.01	SERATED WASHER D6	12
0021.15	WATER SEAL LP. D15 ^B	3	1502.15	PIN D7X25.5	3
0023.22	RING D6.3X9X1.3 2021 "PN/C/G" ^{CE}	3	1506.26	SNAP RING D20	1
0023.25	INTERMEDIATE RING D15 "PN"	3	1603.64	PLUG G3/8	1
0031.49	HOLLOW SHAFT "PN" D3/4"	1	1603.67	PLUG G1/4	1
0103.41	CONNECTING ROD "PN/PS"	3	1603.69	OIL PLUG G1/4+GASKET	1
0208.70	COVER "PN"	1	1603.72	VALVE PLUG "PN" PISTON D15/18 ^E	6
0208.72	BACK COVER "PN"	1	1604.59	HEAD "PN" PISTON D15/18 ^E	1
0209.56	CRANKCASE "PN/PS"	1	1625.10	OIL PLUG G3/8 "PN"	1
0214.21	BALL BEARING D20X52X15	1	1805.19	ALLEN BOLT M6X25	4
0301.42	SLINGER RING "PN/PK/PKWT/PS" ^D	3	1805.20	ALLEN BOLT M6X16	8
0303.18	NUT "PN/PK/PKWT/PS M8XH5" ^D	3	1805.39	ALLEN BOLT M6X60	8
0517.07	ENGINE FLANGE "PN" HP2/5	1	6006.25	VALVE ASSY "PN" W/O O-RING ^{AE}	6
0602.76	BACK COVER GASKET "PN/PK/PW/PS"	1	6017.20	COMPLETE MANIFOLD ASSEMBLY	1
0605.09	GASKET D17X23X1.5 (G3/8)	1	6061.01	KIT 1 - VALVE KIT "PN/PW"	1
0605.33	GASKET D8X14X2 ^D	3	6061.07	KIT 7 - WATER SEAL KIT D15 "PN/PK"	1
0605.49	GASKET D13X19X1.5	1	6061.13	KIT 13 - BRASS RING KIT D15 "PN"	1
0614.15	SET SCREW M8X8	1	6061.20	Kit 20 - PLUNGER KIT D15/18 "PN"	1
0635.01	HIGH PRESS. SEAL ASSY D15 ^B	3			
1101.A2	O-RING - VALVE CAP ^E	6			
1101.A3	O-RING - VALVE ^{AE}	6			
1101.A4	O-RING - PLUNGER ^D	3			
1101.A6	O-RING - BEARING COVER	1			

A Parts in 6061.01 (Kit 1).
 B Parts in 6061.07 (Kit 7).
 C Parts in 6061.13 (Kit 13).
 D Parts in 6061.20 (Kit 20).
 E Parts in 6017.20 (Complete Manifold Assembly).

*Dimensional Drawings are
Shown in Millimeters.
To Convert to Inches,
Multiply Dimension x 0.03937*

PN SERIES PUMPS - 3/4" HOLLOW SHAFT w/ GAS ENGINE FLANGE

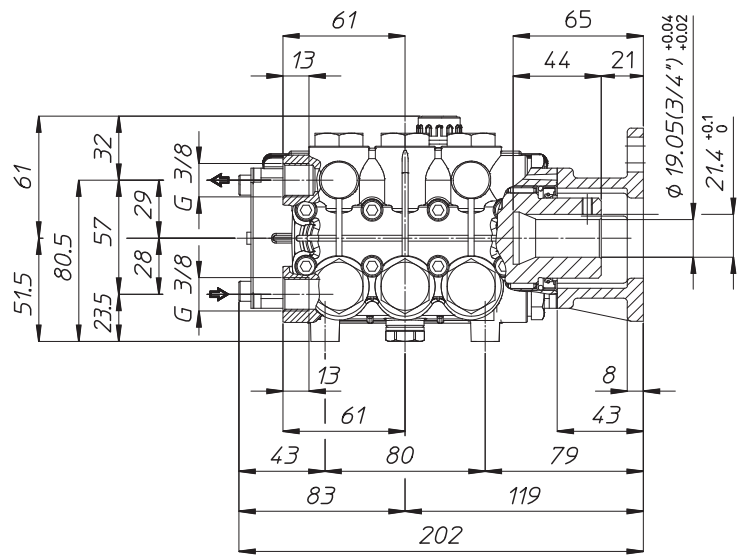
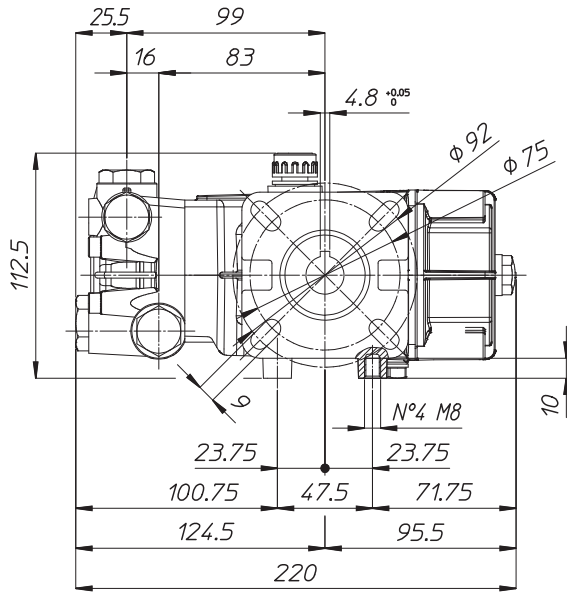

TORQUE SPECS

Ref.	Description	Ft./lb.	Nm	Loctite®
1	Head Bolts	8	11	-
2	Valve Caps	75	100	243
3	Inlet Cap	60	80	-
4	Outlet Cap	60	80	243
5	Bearing Flange Bolts	8	11	-
6	Rear Cover Bolts	8	11	-
7	Connecting Rod Bolts	-	-	-
8	Plunger Bolts	11	15	270
9	Valve Cover Bolts	-	-	-
10	Oil Drain Plug	6	8	-

