

PARTS BREAKDOWN FOR MODEL FH3 & EL-FHT  
RICE HYDRO, INC.

PART NUMBER..	DESCRIPTION..	QTY REQ'D
UD04-0006.09	BEARING	1
UD04-0007.18	SEAL	3
UD04-0007.24	SEAL	1
UD04-0009.09	RETAINER CLIP	1
UD04-0014.20	PLUNGER ROD	3
UD04-0021.15	WATER SEAL	3
UD04-0023.22	SUPPORT RING	3
UD04-0023.25	INTERMEDIATE RING	3
UD04-0031.45	CRANKSHAFT	1
UD04-0103.41	ALUMINUM CONNECTING ROD	3
UD04-0208.70	BACK COVER	1
UD04-0208.72	CRANKCASE COVER	1
UD04-0209.56	CRANKCASE	1
UD04-0214.21	BEARING	1
UD04-0301.42	SLINGER RING	3
UD04-0303.18	PLUNGER NUT	3
UD04-0517.08	ELECTRIC FLANGE	1
UD04-0602.76	BACK COVER GASKET	1
UD02-0605.09	GASKET	1
UD04-0605.33	GASKET	3
UD04-0605.49	GASKET	1
UD04-1101.A2	O-RING - VALVE CAP	6
UD04-1101.A3	O-RING - VALVE	6
UD04-1101.A4	O-RING - PLUNGER	3
UD04-1101.A6	O-RING - BEARING COVER	1
UD04-1101.A7	O-RING - LP SEL RETAINER	3
UD04-1205.35	PLUNGER	3
UD04-1212.10	SIDE PLATE	1
UD04-1221.11	LOW PRESSURE SEAL RETAINER	3
UD04-1411.01	WASHER	12
UD04-1502.15	CONNECTING ROD PIN	3
UD04-1506.26	SNAP RING	1
UD04-1603.64	3/8" PLUG	1
UD02-1603.67	DRAIN PLUG	1
UD04-1603.69	SIGHT GLASS	1
UD04-1603.72	VALVE CAP	6
UD04-1604.C7	ALUMINUM MANIFOLD	1
UD04-1625.10	OIL VENT CAP	1
UD04-1805.19	BOLT	4
UD04-1805.20	BOLT	8
UD04-1805.39	BOLT	8
MOTOR-1HP-CFACE	1HP 110/220V 1 PHASE 50/60HZ	1
SPEC-PND-3.0/15-ZA	TRIPLEX PLUNGER PUMP	1
CHECKVALVE-1/2F	1/2" FEMALE CHECKVALVE	1
BALLVALVE-1/2	1/2" BLEED VALVE	1
BALLVALVE-S-1&1/2	STAINLESS STEEL BALLVALVE	5
GAUGE-600	0-600 PSI LIQUID GAUGE	1
VALVE-RELIEF-500PSI	50-500 PSI PRESSURE REGULATOR	1
HOSE-1/2X2-RH	FH SERIES HOSE	1
SWIVEL-INLET-FH3	2&1/2" FEMALE SWIVEL INLET	1
ADAPTER-NST-1&1/2	1&1/2" NPT X NST OUTLET ADAPTER	4
CASTER-SWIVEL-4	4" SWIVEL CASTER	2
CASTER-RIGID-4	4" RIGID CASTER	2
LABEL-KIT-FH	INSTRUCTION AND CAUTION STICKERS	1
KITS:		
UD04-6061.01	VALVE KIT (KIT 1)	
UD04-6061.07	SEAL KIT (KIT 7)	
UD04-6061.13	BRASS KIT 15MM (KIT 13)	
UD04-6061.20	PLUNGER O-RING KIT (KIT 20)	

MAX FLOW  
MAX PRESSURE  
RATED PUMP SPEED  
POWER REQUIREMENT  
LUBRICATION

3.0 GPM / 11 L/MIN  
1500 PSI / 100 BAR  
1750 RPM  
4.0 HP ELECTRIC  
14 OZ UDOR LUBE

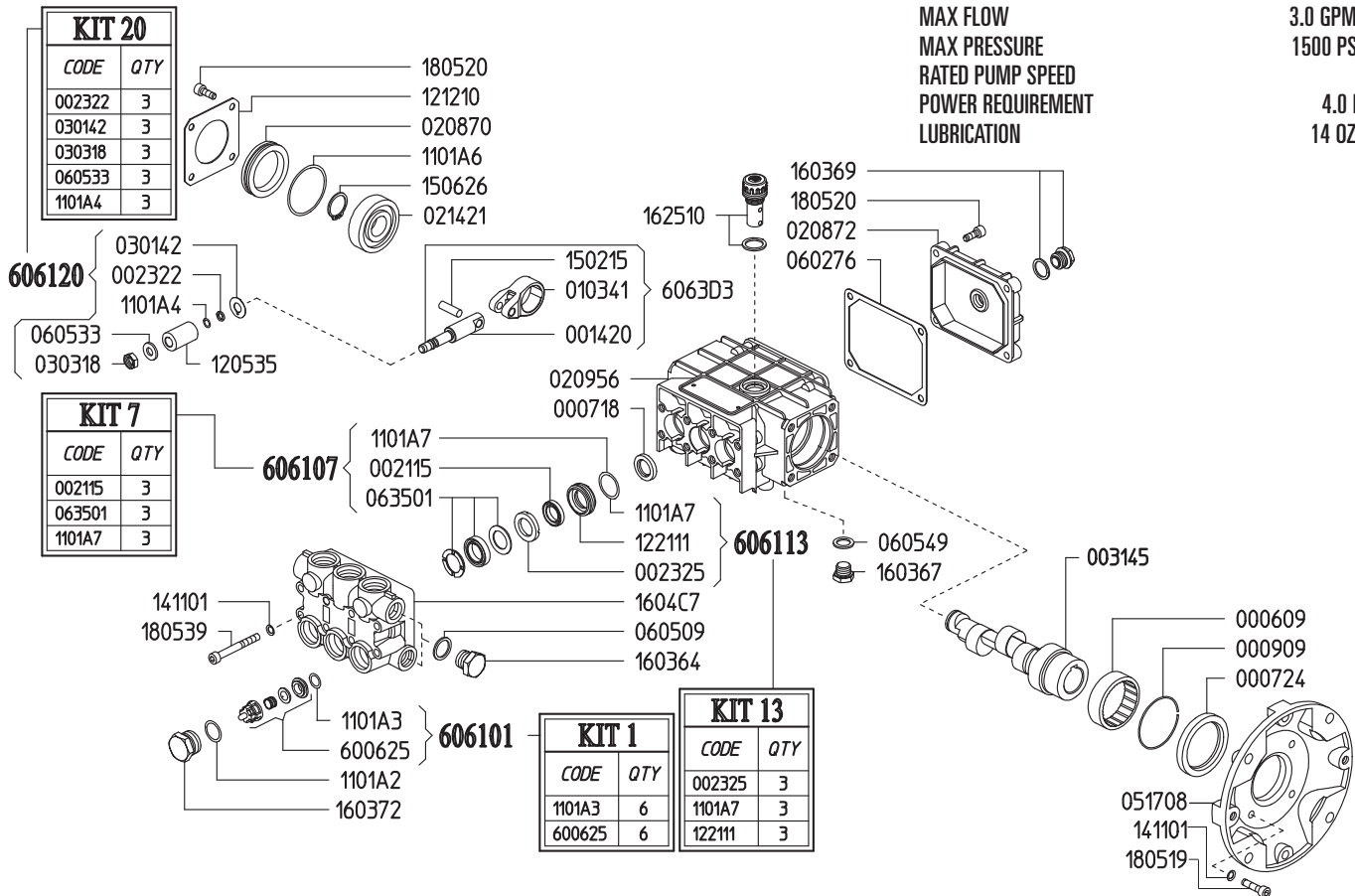

Part #	Description	Qty
0006.09	BUSHING D45X52X16 HK45-16	1
0007.18	OIL SEAL D15X24X4	3
0007.24	OIL SEAL D40X52X7	1
0009.09	ELASTIC RING D52X2.5	1
0014.20	PLUNGER GUIDE D15/18 "PN"	3
0021.15	WATER SEAL LP. D15 <sup>B</sup>	3
0023.22	RING D6.3X9X1.3 2021 "PN/C/G" <sup>C</sup>	3
0023.25	INTERMEDIATE RING D15 "PN"	3
0031.45	HOLLOW SHAFT "PN" D5/8" ECC=5.25	1
0103.41	CONNECTING ROD "PN/PS"	3
0208.70	COVER "PN"	1
0208.72	BACK COVER "PN"	1
0209.56	CRANKCASE "PN/PS"	1
0214.21	BALL BEARING D20X52X15	1
0301.42	SLINGER RING "PN/PK/PKWT/PS" <sup>D</sup>	3
0303.18	NUT "PN/PK/PKWT/PS M8XH5 <sup>D</sup>	3
0517.08	ENGINE FLANGE "PN" NEMA 56H	1
0602.76	BACK COVER GASKET "PN/PK/PW/PS"	1
0605.09	GASKET D17X23X1.5 (G3/8)	1
0605.33	GASKET D8X14X2 <sup>D</sup>	3
0605.49	GASKET D13X19X1.5	1
0635.01	HIGH PRESS. SEAL ASSY D15 <sup>B</sup>	3
1101.A2	O-RING - VALVE CAP	6
1101.A3	O-RING - VALVE <sup>A</sup>	6
1101.A4	O-RING - PLUNGER <sup>D</sup>	3

Part #	Description	Qty
1101.A6	O-RING - BEARING COVER	1
1101.A7	O-RING - LP SEAL RETAINER <sup>B,C</sup>	3
1205.35	CERAMIC PLUNGER D15X30 "PN"	3
1212.10	METAL COVER "PN"	1
1221.11	LOW PRESS. SEAL RETAINER D15 <sup>C</sup>	3
1411.01	SERATED WASHER D6	12
1502.15	PIN D7X25.5	3
1506.26	SNAP RING D20	1
1603.64	PLUG G3/8	1
1603.67	PLUG G1/4	1
1603.69	OIL PLUG G1/4+GASKET	1
1603.72	VALVE PLUG "PN" PISTON D15/18 <sup>A</sup>	6
1604.C7	HEAD "PN" PISTON D15/18 ALUMINUM	1
1625.10	OIL PLUG G3/8 "PN"	1
1805.19	ALLEN BOLT M6X25	4
1805.20	ALLEN BOLT M6X16	8
1805.39	ALLEN BOLT M6X60	8
6006.25	VALVE ASSY "PN" W/O O-RING <sup>A</sup>	6
6061.01	KIT 1 - VALVE KIT "PN/PW"	1
6061.07	KIT 7 - WATER SEAL KIT D15 "PN/PK"	1
6061.13	KIT 13 - BRASS RING KIT D15 "PN"	1
6061.20	Kit 20 - PLUNGER KIT D15/18 "PN"	1

<sup>A</sup> Parts in 6061.01 (Kit 1).  
<sup>B</sup> Parts in 6061.07 (Kit 7).  
<sup>C</sup> Parts in 6061.13 (Kit 13).  
<sup>D</sup> Parts in 6061.20 (Kit 20).

*Dimensional Drawings are  
Shown in Millimeters.  
To Convert to Inches,  
Multiply Dimension x 0.03937*

## PN SERIES PUMPS - 5/8" HOLLOW SHAFT w/ NEMA 56C FLANGE

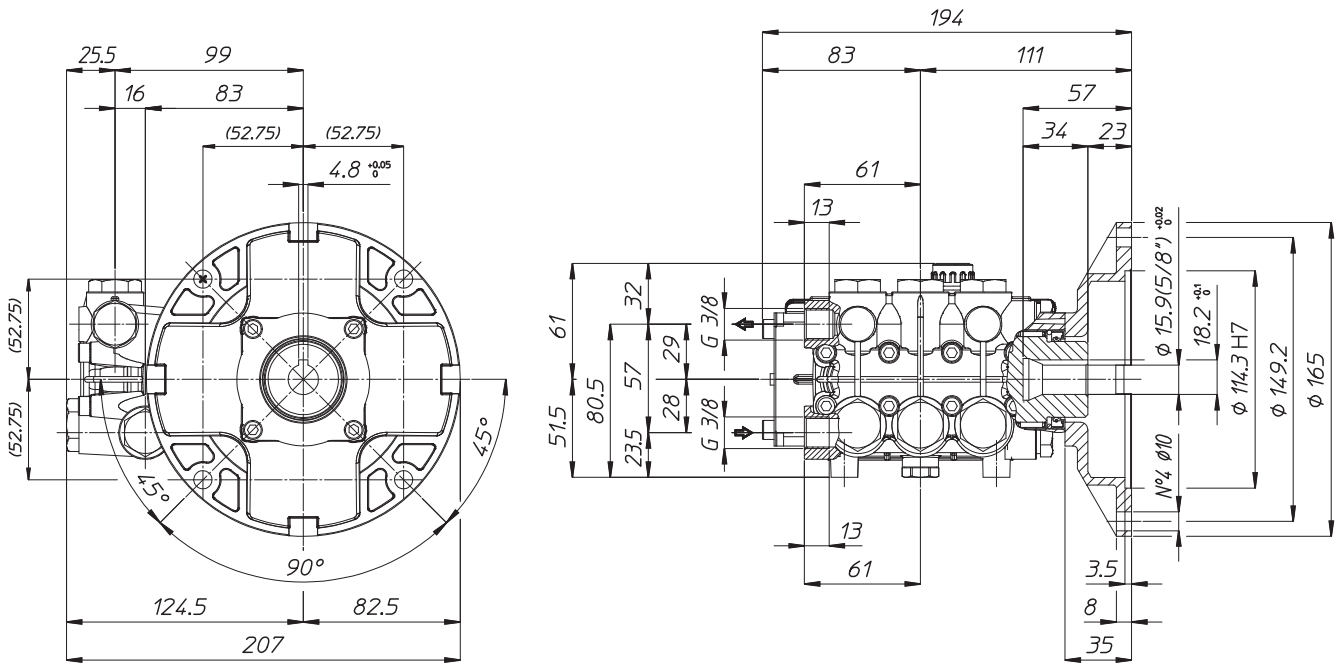

## TORQUE SPECS

Ref.	Description	Ft./lb.	Nm	Loctite®
1	Head Bolts	8	11	-
2	Valve Caps	75	100	243
3	Inlet Cap	60	80	-
4	Outlet Cap	60	80	243
5	Bearing Flange Bolts	8	11	-
6	Rear Cover Bolts	8	11	-
7	Connecting Rod Bolts	-	-	-
8	Plunger Bolts	11	15	270
9	Valve Cover Bolts	-	-	-
10	Oil Drain Plug	6	8	-

