

PARTS BREAKDOWN MODEL DIRTDAGW TORQUE
RICE HYDRO INC.

MAIN FRAME SECTION:

REF#..	PART NUMBER..	DESCRIPTION..	QTY
1	DD-MAIN-FRAME	WELD/COATED MAIN FRAME ASSEMBLY	1
2	HITCH-COUPLER-2"	TOWING HITCH FOR 2" BALL	1
3	BOLT-1/2X13X4-GR8	BOLT TO CONNECT HITCH COUPLER	2
4	FLATWASHER-1/2-GR8	WASHERS FOR HITCH COUPLER	4
5	LOCKNUT-1/2X13-GR8	LOCKNUTS FOR HITCH COUPLER, CLAMP	3
6	HITCHPIN-5/16X2&3/4	SAFETY PIN FOR AXLES, HITCH, BIT	1
8	CHAIN-AUGER-5/16X30	30" 5/16 CHAIN FOR AUGER TOW HITCH	36
9	QUICK-LINK	QUICK LINK FOR 5/16" CHAIN	2
10	DD-LOCKING-HANDLE	HANDLE FOR CLAMP ON MAIN FRAME	1
N/A	COUPLING-BRASS-3/4	3/4" BRASS COUPLING	1
N/A	BOLT-1/2X13X2&1/2	BOLT CLAMP TO MAIN FRAME	1

TANK SECTION:

1	DD-TANK	FLUID RESERVOIR W/COUPLINGS	1
2	3/4MNPT X 3/4MJICX90	FITTING SUCTION HOSE AT TANK	1
3	FILTER-AUGER-3/4	HYDRAULIC FILTER RETURN TO TANK	1
4	NIP-G-3/4X3&1/2	NIPPLE FROM FILTER TO TANK COUPLING	1
5	1/2MJIC X 3/4MNPTX90	FITTING RETURN VALVE TO FILTER/TANK	1
6	NIP-G-3/4X1&1/2	NIPPLE FROM TANK TO BREATHER CAP	1
7	EL-G-3/4X90	ELBOW FROM TANK TO BREATHER CAP	1
8	NIP-G-3/4X3	NIPPLE FROM TANK TO BREATHER CAP	1
9	COUPLING-BRASS-3/4	COUPLING FROM TANK TO BREATHER CAP	1
10	BREATHER-CAP	HYDRAULIC FLUID BREATHER & FILL	1
11	BOLT-3/8X16X1&1/4GR8	TANK BOLTS	8
12	FLATWASHER-5/16-GR8	WASHER FOR TANK BOLTS	16
13	LOCKNUT-3/8X16-GR8	LOCKNUTS FOR TANK BOLTS	8
14	SIGHT-GLASS-DD	FLUID SIGHT GLASS SIDE OF TANK	1
N/A	PLUG-S-1/2	DRAIN PLUG FOR HYDRAULIC FLUID	1

ENGINE CRADLE AND PUMP SECTION:

1	DD-ENGINE-CRADLE	WELDED ASSEMBLY FOR PUMP AND ENGINE	1
2	HONDA-GX270UTQA2	9 HP HONDA ENGINE W/OIL ALERT	1
3	COUPLING-LVJ-ENG-1"	ENGINE SHAFT SIDE	1
4	CENTERDISK-LVJ-AUGER	BUNA SPIDER DISK FOR COUPLINGS	1
5	COUPLING-LVJ-PMP-1/2	PUMP SHAFT SIDE	1
6	HYD-PUMP-MOUNT BF3	PUMP MOUNT TO ENGINE 2 BOLT PATTERN	1
7	HYD-PUMP-MOUNT-COVER	ORANGE SAFETY COVER FOR SHAFT	1
8	HYDRAULIC-PUMP-T	FLUID PUMP TORQUE UNITS	1
9	1/2MJIC X 1/2MOR X90*	FITTING PUMP TO VALVE 72" HOSE SIDE	1
	<i>*UNITS BEFORE SERIAL NUMBER 24135</i>		
9	1/2MJIC X 1/2MOR*	FITTING PUMP TO VALVE 72" HOSE SIDE	1
	<i>*UNITS STARTING WITH SERIAL NUMBER 24135 AND ON</i>		
10	3/4MJIC X 5/8MOR X90	FITTING PUMP TO TANK SUCTION HOSE	1
11	AUGER-FL-SLV-BEARING	SLEAVE BEARING BOLT HOLE ON CRADLE	2
12	WASHER-LEATHER-5/8"	WASHER BETWEEN CRADLE AND FRAME	2
13	BOLT-5/16X18X1&3/4-8	MOUNTING BOLTS FOR ENGINE	4
14	FLATWASHER-5/16-GR8	WASHER FOR BOLTS ENGINE MOUNTING	8
15	LOCKNUT-5/16X18	LOCKNUTS ENGINE MOUNTING	4
16	BOLT-3/8X16X1&1/4GR8	BOLT FOR PUMP MOUNT TO ENGINE	4
17	FLATWASHER-5/16-GR8	WASHER FOR BOLTS ENGINE MOUNTING	4
18	BOLT-5/16X18X1-GR8	BOLT HYD PUMP TO MOUNT	2
19	FLATWASHER-5/16-GR8	WASHER FOR BOLTS ENGINE MOUNTING	2
20	BOLT-1/2X13X1&3/4GR8	BOLT ENGINE CRADLE TO FRAME	2
21	FLATWASHER-1/2-GR8	WASHER FROM ENGINE CRADLE TO FRAME	4
22	LOCKNUT-1/2X13-GR8	NUTS FOR BOLTS FROM CRADLE TO FRAME	2
23	KEY	HYDRAULIC KEY	1
24	KEY	ENGINE KEY	1
N/A	LOCKNUT-5/16X18	LOCKNUT ON TOP ENGINE CRADLE STOP	1
N/A	LOCKNUT-1/4X20	LOCKNUT ON TOP ENGINE CRADLE STOP	1
N/A	DD-SWV-ENGINE-STOP	BRACKET FOR ENGINE SWIVEL STOP	1

PARTS BREAKDOWN MODEL DIRTDAGW TORQUE
RICE HYDRO INC.

HANDLE SECTION:

REF#..	PART NUMBER..	DESCRIPTION..	QTY
1	DD-HANDLE-ASSY	COMPLETE HANDLE SECTION	1
2	DD-MOTOR-PLATE-ASSY	COMPLETE MOTOR PLATE	1
3	HYD-VALVE-T	FLUID VALVE FOR TORQUE DIRTDAGWS	1
4	HYD-MOTOR-T	HYDRAULIC DRIVE MOTOR	1
5	STEL-HP-1/2X90	ELBOW	2
7	1/2MJIC X 5/8MOR X90	MOTOR TO VALVE	2
8	DD-CONTROL-HANDLE	FORWARD AND REVERSE CONTROLS	1
9	DD-CONTROL-ROD-ASSY	CONNECTS CONTROL HANDLE TO VALVE	1
10	BOLT-5/16X18X1&3/4	BOLT TO MOUNT VALVE TO PLATE	3
12	LOCKNUT-5/16X18	NUTS FOR MOUNTING VALVE TO PLATE	3
13	BOLT-1/4X20X1&1/4GR8	CONTROL ROD TO CONTROL HANDLE	2
14	FLATWASHER-1/4	WASHER FOR BOLT CONTROL ROD	4
15	LOCKNUT-1/4X20	NUT FOR CONTROL ROD	2
16	BOLT-1/2X13X1&3/4GR8	MOUNTING MOTOR TO MOTOR PLATE	4
17	FLATWASHER-1/2-GR8	WASHERS FOR BOLTS MOUNTING MOTOR	6
18	LOCKNUT-1/2X13-GR8	NUT FOR MOUNTING MOTOR	4
19	BOLT-10-24X1&1/4HEX	CONNECTS CONTROL TO VALVE	1
20	LOCKNUT-10X24	NUT FOR BOLT ROD TO VALVE	1
21	HITCHPIN-3/8X2&3/4	LOCKING PIN MOTOR PLATE	1
23	FLATWASHER-3/8-GR8	HANDLE ASSY INTERNAL ROD CAPTURE	1
24	BOLT-10/24X3/4"	HOLDS CAPTURE ROD HANDLE ASSY	1
25	LOCKNUT-10X24	NUT FOR BOLT ON CAPTURE	1

HOSE ASSEMBLY SECTION:

1	<u>HOSE VALVE TO MOTOR</u>		
	HOSE-1/2-2500XFT	HYDRAULIC PRESSURE HOSE BY FOOT 32"	2.8
	FITTING-1/2FJIC	FEMALE JIC VALVE TO MOTOR	1
	FITTING-1/2MPIPE	MALE RIGID VALVE TO MOTOR	1
2	<u>HOSE VALVE TO MOTOR</u>		
	HOSE-1/2-2500XFT	HYDRAULIC PRESSURE HOSE BY FOOT	3
	FITTING-1/2FJIC	FEMALE JIC VALVE TO MOTOR	1
	FITTING-1/2MPIPE	MALE RIGID VALVE TO MOTOR	1
3	<u>HOSE RETURN TO TANK</u>		
	HOSE-1/2-2500XFT	HYDRAULIC PRESSURE HOSE BY FOOT 42"	3.5
	FITTING-1/2FJIC	FILTER RETURN TO TANK	1
	FITTING-1/2MPIPE	OUTLET VALVE TO TANK RETURN	1
4	<u>HOSE PUMP TO INLET VALVE</u>		
	HOSE-1/2-2500XFT	HYDRAULIC PRESSURE HOSE BY FOOT	6
	FITTING-1/2FJICX90	PUMP TO INLET VALVE	1
	FITTING-1/2MPIPE	INLET VALVE FROM PUMP	1
5	<u>HOSE SUCTION FROM TANK</u>		
	HOSE-3/4-1250XFT	HYDRAULIC PRESSURE HOSE BY FOOT	3
	FITTING-3/4FJIC	PUMP INLET FROM TANK RESERVOIR	2

PARTS BREAKDOWN MODEL DIRTDAGW TORQUE
RICE HYDRO INC.

AXLE ASSEMBLY SECTION:

REF#..	PART NUMBER..	DESCRIPTION..	QTY
1	DD-AXLE-PLATE-ASSY	WELDED PLATE AND TUBES	1
2	HUB-ASSY-MANUAL-PROP	WHEEL HUB	2
		<i>**includes #4 bearing and #6 seal</i>	
3	NUT-CASTLE-1"-12SLOT	CASTLE NUT FOR WHEEL HUB	2
4	BEARING	KIT #2 WHEEL BEARINGS W/SEALS #6	2
5	WHEEL-18.5"-4PLY	HIGHWAY RATED TIRES	2
6	SEAL-G5-2	SEAL (INCLUDED W/ BEARING)	2
7	AXLE-DIRTDAGW-1&1/4	MACHINE THREADED STEEL AXLES	2
8	COTTERPIN-1/8X1&3/4	COTTERPIN	2
9	HITCHPIN-5/16X2&3/4	SAFETY PIN FOR AXLES, HITCH, BIT	2
N/A	SETSCREW-3/8X16X3/4	SOCKET SETSCREW	2
N/A	BEARING-BUDDIES	SELF LUBRICATING BEARINGS (PAIR)	1
N/A	BEARING-BUDDY-BRA	BEARING BUDDY COVERS (PAIR)	1

ADAPTERS:

N/A	ADAPTER-7/8-STD	7/8" SQUARE DRIVE ADAPTER	1
N/A	ADAPTER-1&1/4-LB	1 & 1/4" FEMALE DRIVE ADAPTER	1
N/A	ADAPTER-1&3/8HEX	1 & 3/8" MALE HEXAGON DRIVE ADPTR	1
N/A	ADAPTER-1&1/4-STIHL	1 & 1/4" ROUND DRIVE ADAPTER	1
N/A	BOLT-3/8X16X3GR8	ADAPTER BOLT - MOTOR SHAFT	1
N/A	LOCKNUT-3/8X16-GR8	LOCKNUT FOR BOLT	1
N/A	HITCHPIN-5/16X2&3/4	CONNECTING AUGER BIT TO ADAPTER	1
N/A	LABEL-KIT-DD	INSTRUCTION AND CAUTION STICKERS	1

AUGER BITS:

AUGER BITS ALSO AVAILABLE IN 42" LENGTH

N/A	AUGER-6-CS-36	6" X 36" AUGER BIT 7/8" SQUARE	1
N/A	AUGER-8-CS-36	8" X 36" AUGER BIT 7/8" SQUARE	1
N/A	AUGER-10-CS-36	10" X 36" AUGER BIT 7/8" SQUARE	1
N/A	AUGER-12-CS-36	12" X 36" AUGER BIT 7/8" SQUARE	1

VARIOUS HUB CONNECTION SIZES AVAILABLE - CONTACT FACTORY

AUGER BIT EXTENSIONS:

OPTIONAL 1 & 3/8" HEX CONNECTION AVAILABLE - CONTACT FACTORY

N/A	AUGER-EXT-7/8X6	7/8" X 6" SQUARE MALE EXTENSION	1
N/A	AUGER-EXT-7/8X12	7/8" X 12" SQUARE MALE EXTENSION	1
N/A	AUGER-EXT-7/8X24	7/8" X 24" SQUARE MALE EXTENSION	1
N/A	AUGER-EXT-7/8X36	7/8" X 36" SQUARE MALE EXTENSION	1

PILOT BITS & TEETH:

N/A	AUGER-PB-SB-25C	CARBIDE TIPPED 2&1/2" PILOT BIT	1
N/A	AUGER-TOOTH-35	STANDARD STEEL DIRT TOOTH, FLAT END	2
N/A	AUGER-TOOTH-RB-36	SOLID CARBIDE "RIDGE BREAKER"	2
N/A	AUGER-TOOTH-1336	INSERT CARBIDE, HARD OR FROZEN SOIL	2

MAIN FRAME

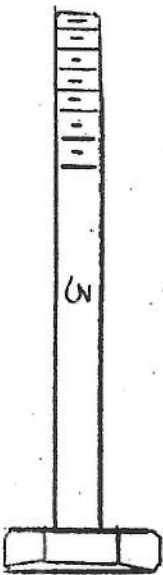
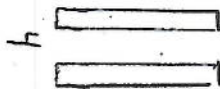
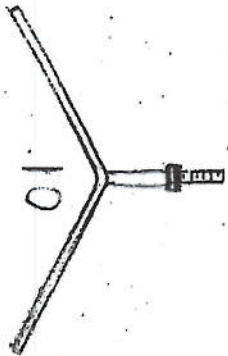
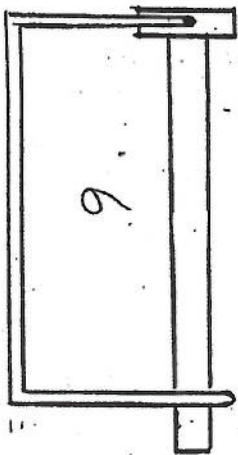
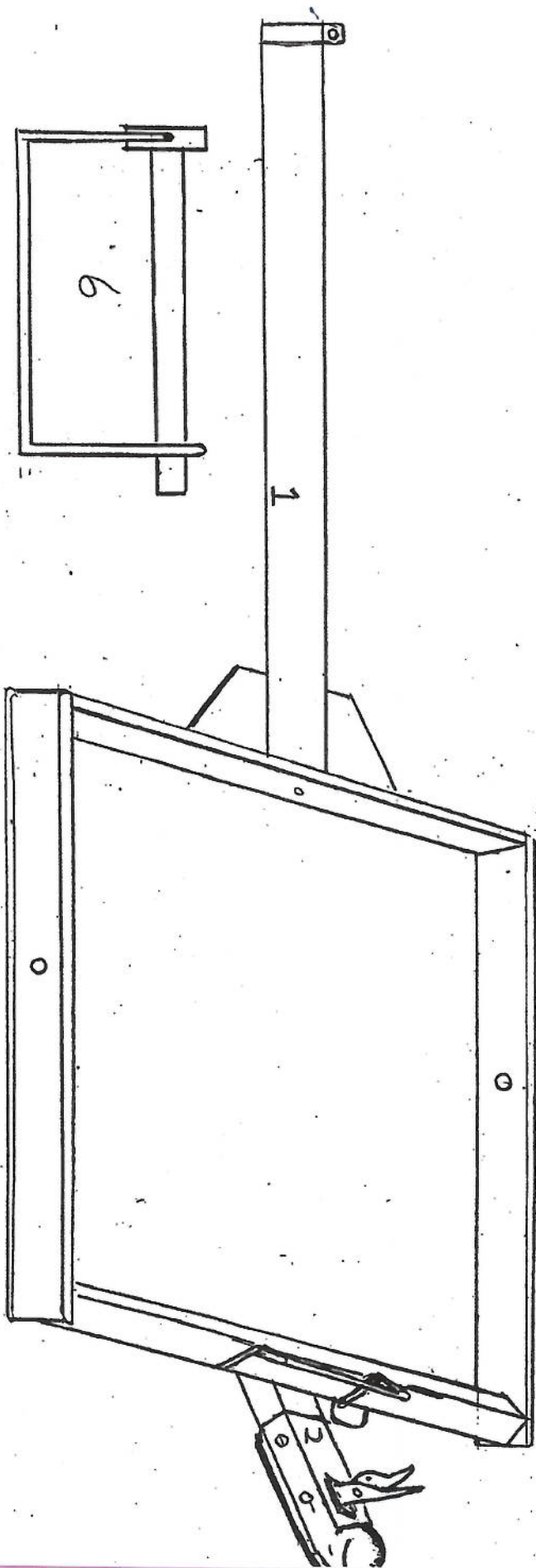
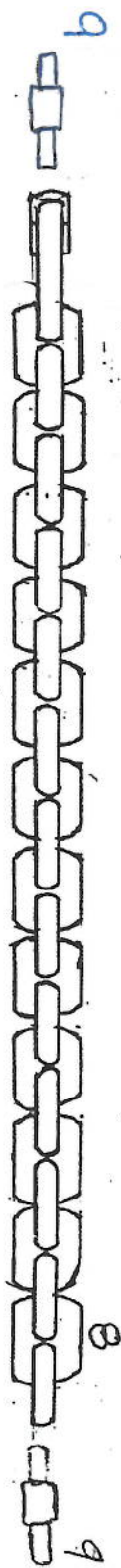

TANK

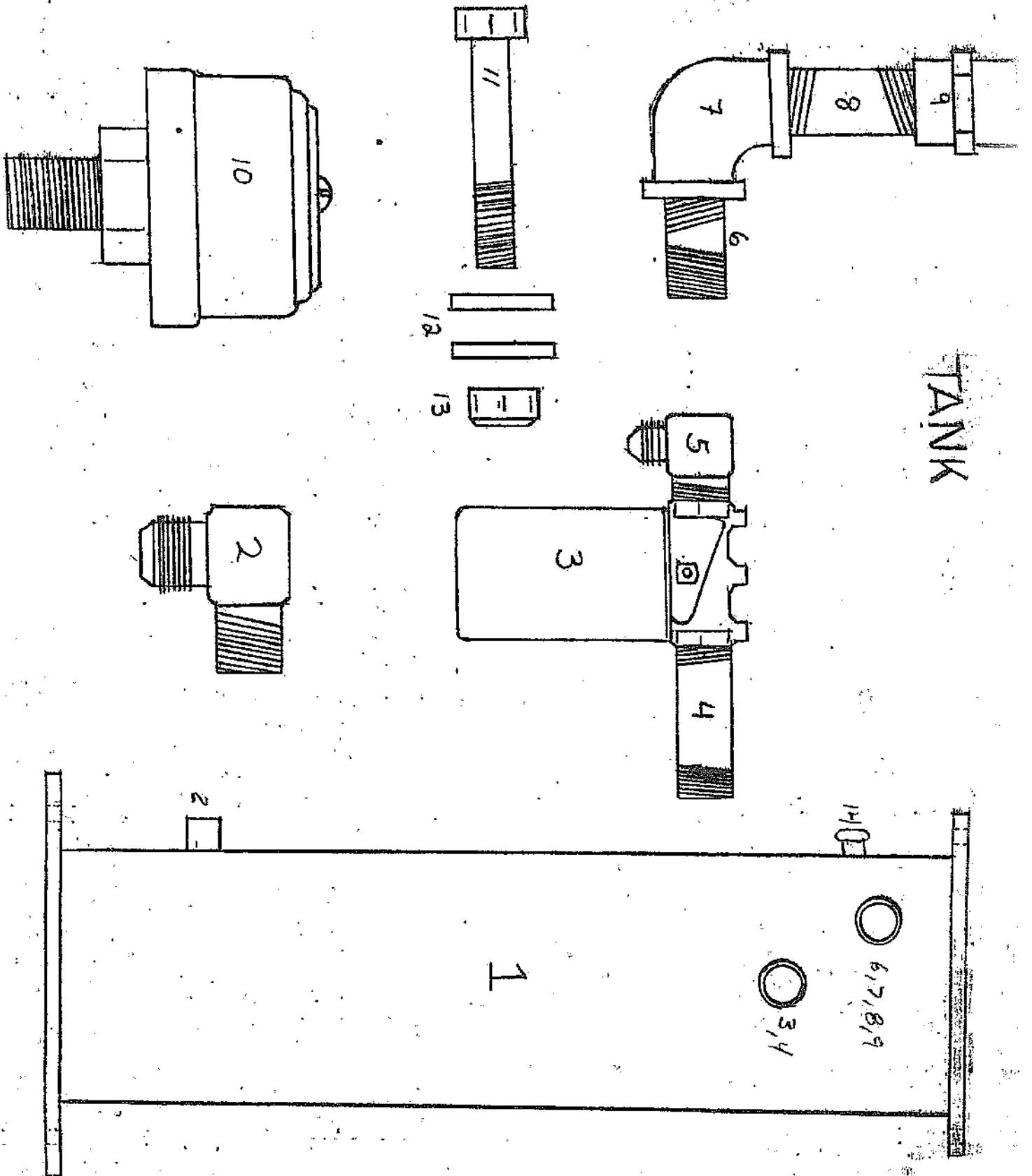

ENGINE CRADLE AND PUMP

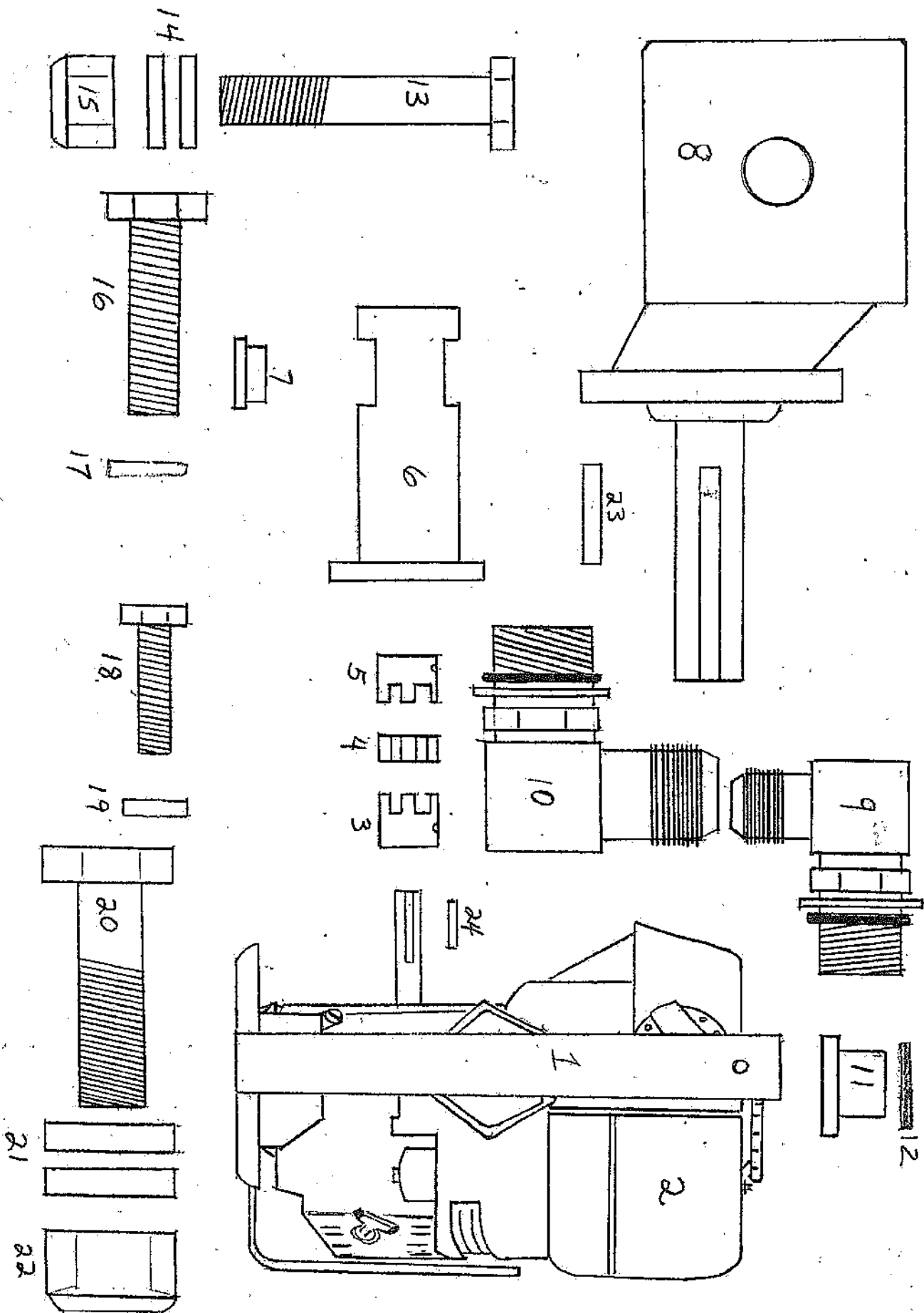

HANDLE 1

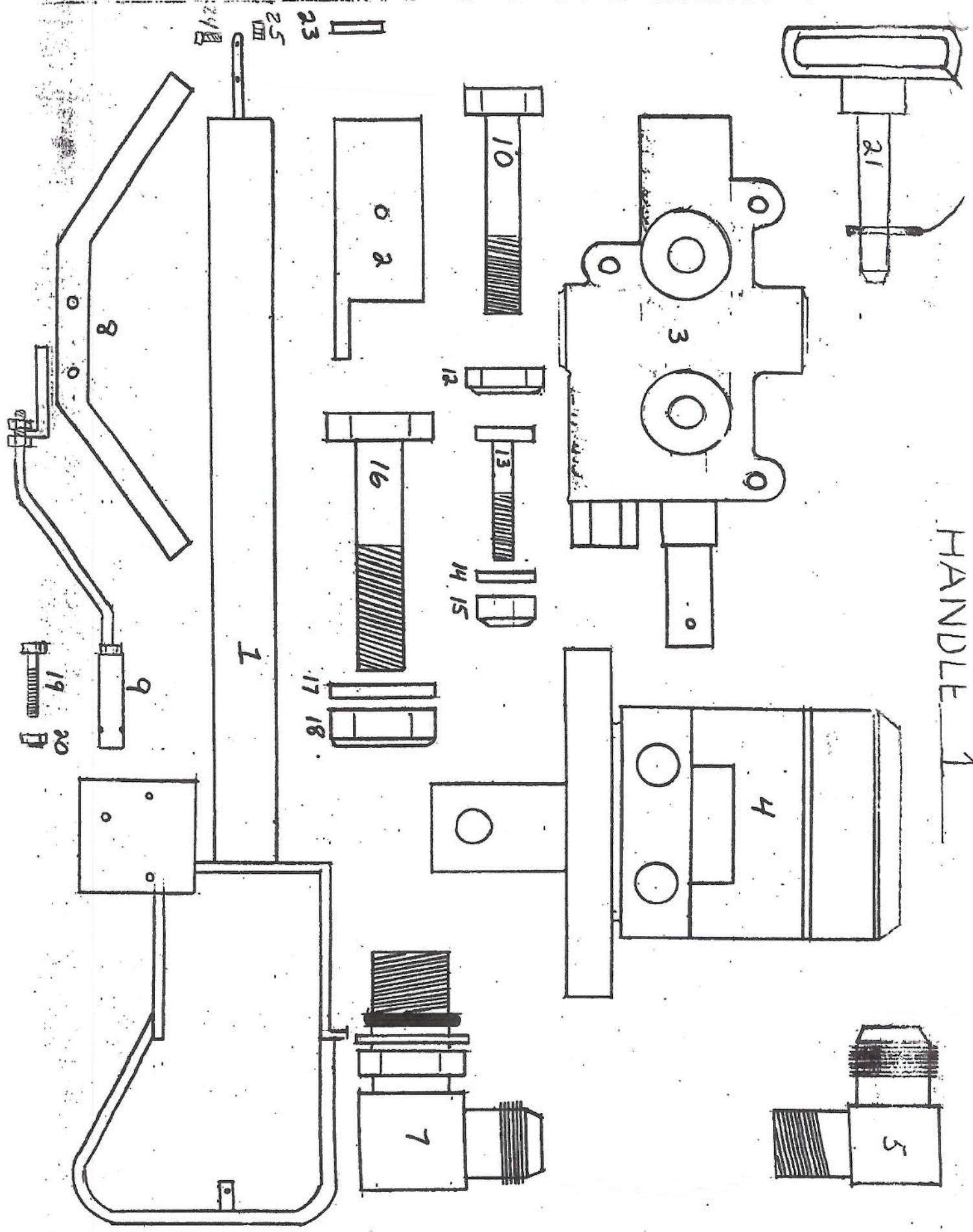

HOSES

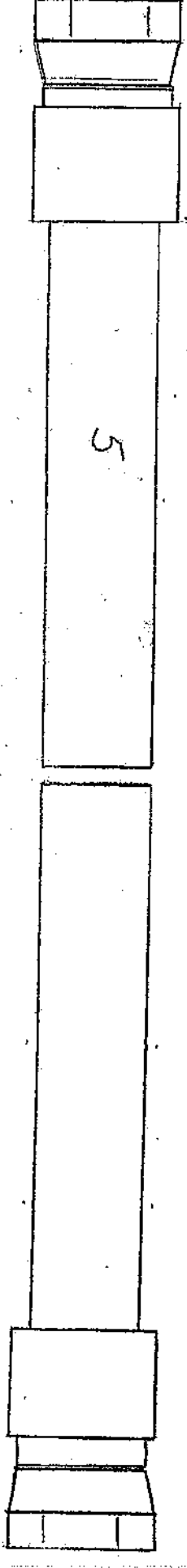
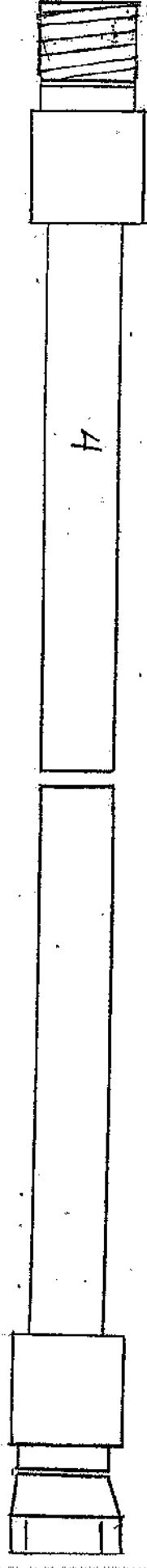
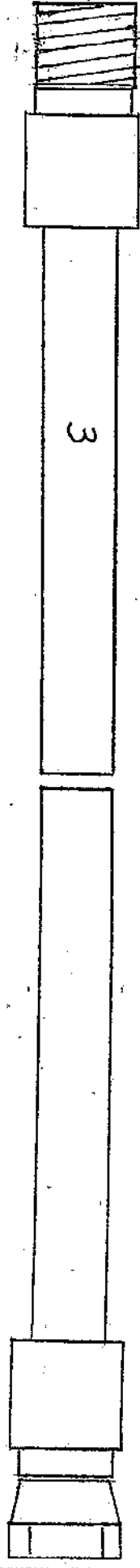
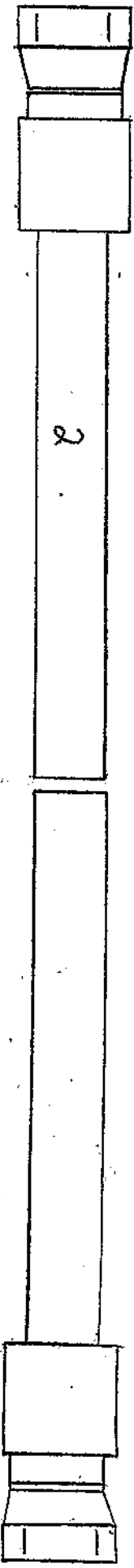

AXLE AND AXLE TUBE

