

Electric Series

Hydrostatic Test Pumps

The EL series is the most versatile and sought-after Electric Hydrostatic Test Pump on the market today. Designed for testing sprinkler systems, irrigation lines, pressure vessels, plant process piping and standard water lines. Models in this series offer “gallon per minute” flow rates from 1.5 to 12.5 (GPM); with “pounds per square inch” testing capability up to 1800 (PSI). RICE units can be “Build to Suit” with various voltage, phase, hertz and explosion-proof motor configurations offered. Contact the factory for special order options available or with your specifications.



EL1A 3 GPM up to 500 PSI

- One year complete product warranty
- Triplex plunger pump with oil inner bath ensures long life
- 1 HP electric motor TEFC, 110 or 220V reads 50/60 HZ
- Stainless Steel liquid filled gauge, ensures accurate readings less flutter
- 8 foot 1/2 inch outlet hose included
- Optional wheel and handle kit



EL1 3 GPM up to 300 PSI

- One year complete product warranty
- Triplex plunger pump with oil inner bath ensures long life
- 1/2 HP electric motor TEFC, 110 or 220V 60 HZ
- Stainless Steel liquid filled gauge, ensures accurate readings less flutter
- 8 foot 1/2 inch outlet hose included
- Optional wheel and handle kit



EL2 1.5 GPM up to 1000 PSI

- One year complete product warranty
- Triplex plunger pump with oil inner bath ensures long life
- 1 HP electric motor TEFC, 110 or 220V reads 50/60 HZ
- Stainless Steel liquid filled gauge, ensures accurate readings less flutter
- 8 foot 3/8 inch outlet hose included
- Optional wheel and handle kit



EL3 1.5 GPM up to 1500 PSI

- One year complete product warranty
- Triplex plunger pump with oil inner bath ensures long life
- 1.5 HP electric motor TEFC, 110 or 220V reads 50/60 HZ
- Stainless Steel liquid filled gauge, ensures accurate readings less flutter
- 8 foot 3/8 inch outlet hose included
- Optional wheel and handle kit



EL-4/18 4 GPM up to 1800 PSI

- One year complete product warranty
- Triplex plunger pump with oil inner bath ensures long life
- 5 HP electric motor TEFC, 1 phase, 230V, 60 HZ
- Stainless Steel liquid filled gauge, ensures accurate readings less flutter
- 8 foot 3/8 inch outlet hose included
- Optional wheel and handle kit



EL-5/500 5 GPM up to 500 PSI

- One year complete product warranty
- Triplex plunger pump with oil inner bath ensures long life
- 2 HP electric motor TEFC, 110 or 220V, 60 HZ
- Stainless Steel liquid filled gauge, ensures accurate readings less flutter
- 8 foot 1/2 inch outlet hose included
- Optional wheel and handle kit



EL-8/12 8 GPM up to 1200 PSI

EL-12.5/300 12.5 GPM up to 300 PSI

- One year complete product warranty
- Triplex plunger pump with oil inner bath ensures long life
- 7.5 HP electric motor TEFC, 3 phase 230 or 460V, 60 HZ
- Stainless Steel liquid filled gauge, ensures accurate readings less flutter
- 8 foot 3/8 inch outlet hose included
- Optional wheel and handle kit

Wheel & Handle Kits



RI-6

- Wheel & handle kit, for small units
- Instantly makes your hydrostatic test pump truly mobile
- Includes heavy duty metal handle and v-rest along with casters and all hardware needed for installation



WK-STD

- Wheel & handle kit, for standard units
- Instantly makes your hydrostatic test pump truly mobile
- Includes heavy duty metal handle, axel and v-rest along with “No Flat” tires and all hardware needed for installation



RI-10

- Wheel & handle kit, for large units
- Instantly makes your hydrostatic test pump truly mobile
- Includes heavy duty metal handle, axel and footrest along with “No Flat” tires and all hardware needed for installation



3500 Arrowhead Drive • Carson City • Nevada 89706

Web: ricehydro.com • Email: sales@ricehydro.com • Phone: 800-245-4777 • Fax: 800-998-7423

RICE HYDRO, INC.
MANUFACTURER'S OPERATING INSTRUCTIONS
EL-SERIES MODEL TEST PUMPS

FOR WARRANTY REGISTRATION CALL: 1-800-245-4777

 **WARNING:** Operating, servicing and maintaining this equipment can expose you to chemicals including engine exhaust, carbon monoxide and lead, which are known to the State of California to cause cancer and birth defects or other reproductive harm. To minimize exposure, avoid breathing exhaust, do not idle the engine except as necessary, operate and service your equipment in a well-ventilated area and wear gloves or wash your hands frequently when servicing your equipment. For more information go to: www.p65warnings.ca.gov

CAUTIONS:

1. Power source must meet voltage, phase, hertz and amperage requirements of electric motor, as stated on label. **If an extension cord is used, requires at least 12 gauge 3 wire with maximum of 25 foot length.**
2. Check ALL fluid levels prior to operating the unit.
3. Use a sound 3/4" or larger supply hose.
4. Protect the pump from freezing, FLUSH with anti-freeze.
5. DO NOT run dry or pump chlorine thru the unit.

CONNECTING THE PUMP:

1. With motor switch in the off position, connect power cord of motor to a standard wall outlet. *Extension cord: when needed, requires a 12 gauge 3 wire, **maximum 25 foot length** plugged into a 20 or larger amp breaker, depending on individual motor requirements.*
2. Connect **CLEAN** pressurized water source to the inlet of the pump. It is recommended that the unit be pressure fed. For gravity feed locate water within 8 feet and elevated above level of unit, and then prime the pump.
3. Connect high-pressure outlet hose to the pump and your test environment.

OPERATING THE PUMP:

1. Turn the outlet ballvalve to the open position, start the motor.
2. The pressure regulator has been preset at the factory. **To change this setting you must make this adjustment while the water is flowing freely, and the unit is under NO pressure.** To adjust the pressure, first loosen the locknut. Turn the T-handle/Knob clockwise to increase and counter-clockwise to decrease the pressure. Place a ballvalve or similar open and close valve at the end of the outlet hose, open and close this valve multiple times as needed, to check pressure setting and re-adjust as necessary. It is also recommended that you open and close the hosebib located under the gauge to bleed excess air from piping and ensure accurate pressure gauge readings. Upon reaching desired pressure setting, tighten locknut and prepare to begin test.
3. With the ballvalve open begin building pressure in the test environment. Be sure to bleed the air from hosebib under gauge at least once during this process. Once test pressure has been reached, close the ballvalve and shut-off motor. An inlet checkvalve prevents water pressure from bleeding back into the pump.
4. Once the outlet ballvalve is closed and your test begins, you have now isolated the test pump from the test environment, any loss of pressure is due to leaks or trapped air being compressed in the test environment.

RECOMMENDED MAINTENANCE

1. Pumps use non-detergent 30wt oil, gear reductions use 90wt gear oil.

MAX FLOW
MAX PRESSURE
RATED PUMP SPEED
POWER REQUIREMENT
LUBRICATION

3.0 GPM 11 L/MIN
2000 PSI / 130 BAR
3400 RPM
4.0 HP ELECTRIC
14 OZ UDOR LUBE

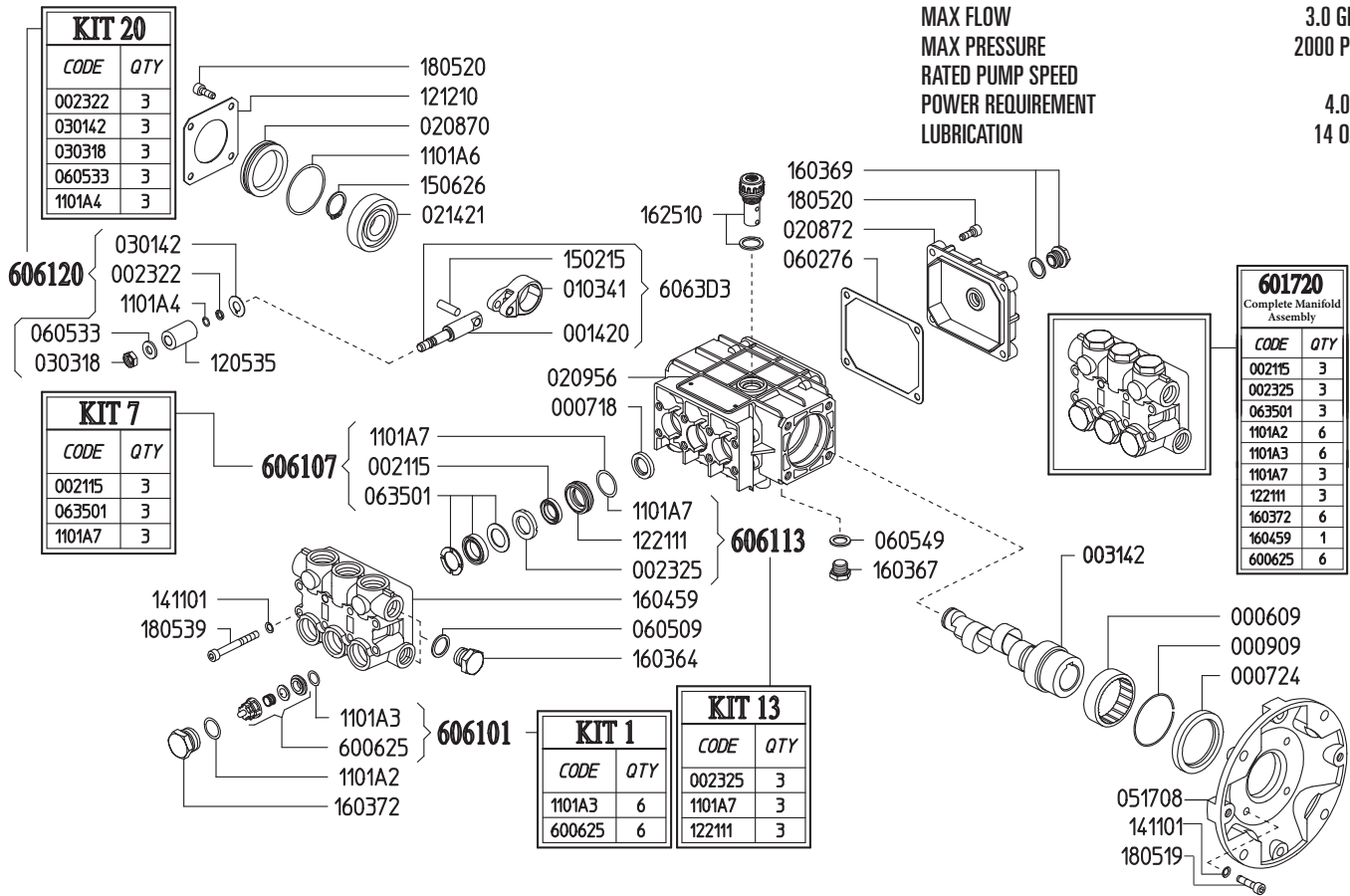

Part #	Description	Qty	Part #	Description	Qty
0006.09	BUSHING D45X52X16 HK45-16	1	1101.A7	O-RING - LP SEAL RETAINER ^{B C E}	3
0007.18	OIL SEAL D15X24X4	3	1205.35	CERAMIC PLUNGER D15X30 "PN"	3
0007.24	OIL SEAL D40X52X7	1	1212.10	METAL COVER "PN"	1
0009.09	ELASTIC RING D52X2.5	1	1221.11	LOW PRESS. SEAL RETAINER D15 ^{C E}	3
0014.20	PLUNGER GUIDE D15/18 "PN"	3	1411.01	SERATED WASHER D6	12
0021.15	WATER SEAL LP. D15 ^{B E}	3	1502.15	PIN D7X25.5	3
0023.22	RING D6.3X9X1.3 2021 "PN/C/G" ^{C E}	3	1506.26	SNAP RING D20	1
0023.25	INTERMEDIATE RING D15 "PN"	3	1603.64	PLUG G3/8	1
0031.42	HOLLOW SHAFT "PN" D5/8"	1	1603.67	PLUG G1/4	1
0103.41	CONNECTING ROD "PN/PS"	3	1603.69	OIL PLUG G1/4+GASKET	1
0208.70	COVER "PN"	1	1603.72	VALVE PLUG "PN" PISTON D15/18 ^E	6
0208.72	BACK COVER "PN"	1	1604.59	HEAD "PN" PISTON D15/18 ^E	1
0209.56	CRANKCASE "PN/PS"	1	1625.10	OIL PLUG G3/8 "PN"	1
0214.21	BALL BEARING D20X52X15	1	1805.19	ALLEN BOLT M6X25	4
0301.42	SLINGER RING "PN/PK/PKWT/PS" ^D	3	1805.20	ALLEN BOLT M6X16	8
0303.18	NUT "PN/PK/PKWT/PS M8XH5" ^D	3	1805.39	ALLEN BOLT M6X60	8
0517.08	ENGINE FLANGE "PN" NEMA 56H	1	6006.25	VALVE ASSY "PN" W/O O-RING ^{A E}	6
0602.76	BACK COVER GASKET "PN/PK/PW/PS"	1	6017.20	COMPLETE MANIFOLD ASSEMBLY	1
0605.09	GASKET D17X23X1.5 (G3/8)	1	6061.01	KIT 1 - VALVE KIT "PN/PW"	1
0605.33	GASKET D8X14X2 ^D	3	6061.07	KIT 7 - WATER SEAL KIT D15 "PN/PK"	1
0605.49	GASKET D13X19X1.5	1	6061.13	KIT 13 - BRASS RING KIT D15 "PN"	1
0635.01	HIGH PRESS. SEAL ASSY D15 ^{B E}	3	6061.20	Kit 20 - PLUNGER KIT D15/18 "PN"	1
1101.A2	O-RING - VALVE CAP ^E	6			
1101.A3	O-RING - VALVE ^{A E}	6			
1101.A4	O-RING - PLUNGER ^D	3			
1101.A6	O-RING - BEARING COVER	1			

^A Parts in 6061.01 (Kit 1).
^B Parts in 6061.07 (Kit 7).
^C Parts in 6061.13 (Kit 13).
^D Parts in 6061.20 (Kit 20).
^E Parts in 6017.20 (Complete Manifold Assembly).

*Dimensional Drawings are
Shown in Millimeters.
To Convert to Inches,
Multiply Dimension x 0.03937*

PN SERIES PUMPS - 5/8" HOLLOW SHAFT w/ NEMA 56C FLANGE

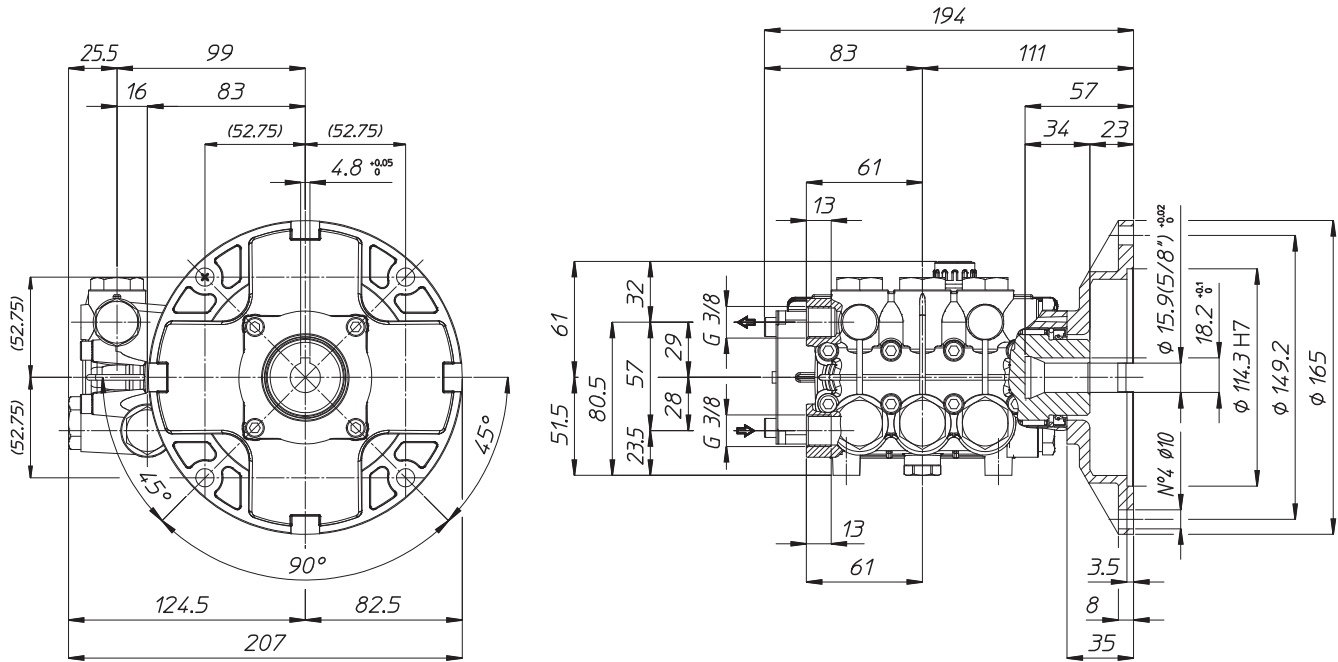

TORQUE SPECS

Ref.	Description	Ft./lb.	Nm	Loctite®
1	Head Bolts	8	11	-
2	Valve Caps	75	100	243
3	Inlet Cap	60	80	-
4	Outlet Cap	60	80	243
5	Bearing Flange Bolts	8	11	-
6	Rear Cover Bolts	8	11	-
7	Connecting Rod Bolts	-	-	-
8	Plunger Bolts	11	15	270
9	Valve Cover Bolts	-	-	-
10	Oil Drain Plug	6	8	-

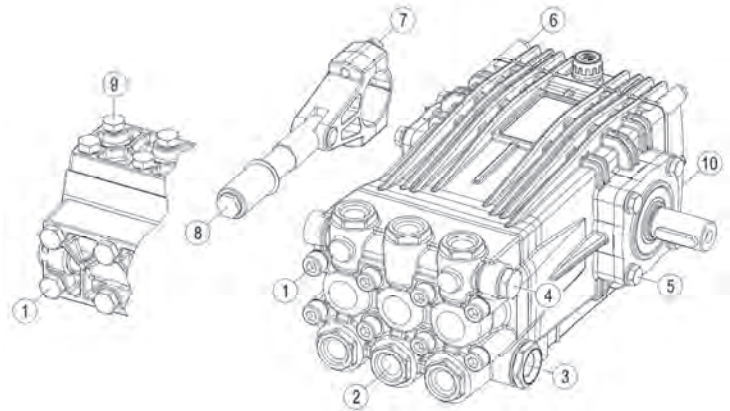

PARTS BREAKDOWN FOR MODELS: EL2, EL3
RICE HYDRO INC.

PART NUMBER..	DESCRIPTION..	QTY REQ'D
UD04-0006.09	BEARING	1
UD04-0007.18	SEAL	3
UD04-0007.24	SEAL	1
UD04-0009.09	RETAINER CLIP	1
UD04-0014.20	PLUNGER ROD	3
UD04-0021.15	WATER SEAL	3
UD04-0023.22	SUPPORT RING	1
UD04-0031.42	CRANKSHAFT	1
UD04-0103.41	ALUMINUM CONNECTING ROD	3
UD04-0208.70	BACK COVER	1
UD04-0208.72	CRANKCASE COVER	1
UD04-0209.56	CRANKCASE	1
UD04-0214.21	BEARING	1
UD04-0301.42	SLINGER RING	1
UD04-0303.18	PLUNGER NUT	1
UD04-0517.08	ELECTRIC FLANGE	1
UD04-0602.76	GASKET - CRANKCASE COVER	1
UD02-0605.09	ALUMINUM WASHER	1
UD04-0605.33	PLUNGER WASHER	1
UD04-0605.49	O-RING	1
UD04-0635.01	HIGH PRESSURE SEAL ASSY	3
UD04-1101.A2	O-RING	6
UD04-1101.A3	VALVE O-RING	6
UD04-1101.A4	O-RING	1
UD04-1101.A6	O-RING	1
UD04-1101.A7	O-RING	3
UD04-1205.35	PLUNGER - 15 MM	3
UD04-1212.10	SIDE PLATE	1
UD04-1221.11	LOW PRESSURE SEAL RETAINER	3
UD04-1411.01	WASHER	12
UD04-1502.15	CONNECTING ROD PIN	3
UD04-1506.26	SNAP RING	1
UD04-1603.64	3/8" PLUG	1
UD02-1603.67	DRAIN PLUG	1
UD04-1603.69	SIGHT GLASS	1
UD04-1603.72	VALVE CAP	6
UD04-1604.59	BRASS MANIFOLD	1
UD04-1625.10	OIL PLUG	1
UD04-1805.19	BOLT	4
UD04-1805.20	BOLT	8
UD04-1805.39	BOLT	8
UD04-6006.25	VALVE ASSY KIT w/o O-RING	6

OUTLET HOSES:

HOSE-3/8X8-RH	8' FOOT OUTLET HOSE - STANDARD	1
<i>*3/8" Male Rigid Fitting & 3/8" Male Swivel Fitting included on 8ft outlet hose</i>		
COUPLERBODY-BR-3/8F	FEMALE PUMP OUTLET - HOSE	1
COUPLERPLUG-3/8M	MALE PUMP OUTLET - PIPING	1
HOSE-3/8-3000XFT	SPECIFY LENGTH OF HOSE	
3/8" Male Rigid Fitting & 3/8" Male Swivel Fitting		1

MOTORS & PUMPS:

MOTOR-1HP-CFACE (EL2)	1HP 110/220V 1 PHASE 50/60HZ	1
MOTOR-1.5HP-50/60HZ (EL3)	1.5HP 110/220V 1 PHASE 50/60HZ	1
SPEC-PNL-3.0/20-Z	TRIPLEX PLUNGER PUMP	1

PARTS BREAKDOWN FOR MODELS: EL2, EL3
RICE HYDRO INC.

PART NUMBER..	DESCRIPTION..	QTY REQ'D
MISCELLANEOUS PARTS:		
HOESWIVEL-1/2	HOSE SWIVEL INLET	1
HOESCREEN&WASHER	INLET HOSE SCREEN	1
BALLVALVE-3/8HP	OUTLET BALLVALVE	1
VALVE-RELIEF-900PSI (EL2) RED SPRING 100-900 PSI	PRESSURE REGULATOR	1
VALVE-RELIEF-2000PSI (EL3) YELLOW SPRING 200-2000 PSI	PRESSURE REGULATOR	1
GAUGE-1500 (EL2)	0-1500 PSI LIQUID GAUGE	1
GAUGE-2000 (EL3)	0-2000 PSI LIQUID GAUGE	1
NEEDLEVALVE-1/4	AIR BLEED VALVE	1
KING-EL1A	SHIPPING BOX	1
LABEL-KIT-EL	INSTRUCTION AND CAUTION STICKERS	1
KITS:	*Kits are all inclusive	
UD04-6061.01	VALVE KIT	
UD04-6061.07	SEAL KIT	
UD04-6061.13	BRASS KIT	
UD04-6061.20	PLUNGER O-RING KIT	