

PARTS BREAKDOWN FOR MODEL DP(H)-3B w/UDOR
RICE HYDRO INC.

PUMP PARTS:

REF#..	PART NUMBER..	DESCRIPTION..	QTY REQD
146	SPEC-00146	BEARING (02-0006.14)	1
157	SPEC-00157	SEAL (02-0007.05)	1
189	SPEC-00189	RETAINING RING (02-0001.11)	2
240	SPEC-00240	DIAPHRAGM BOLT (02-0102.04)	3
357	SPEC-00357	SUCTION ELBOW (02-0202.18)	1
513	SPEC-00513	PISTON SLEEVE (02-0206.41)	3
540	SPEC-00540	OIL RESERVOIR CAP (02-0208.98)	1
592	SPEC-00592	CRANKCASE (02-0209.73)w/BEARING (02-0006.14)	1
701	SPEC-00701	BEARING (02-0214.05)	1
808	SPEC-00808	RETAINING WASHER (02-0301.43)	3
816	SPEC-00816	SPACER (02-0301.54)	1
817	SPEC-00817	SPACER (02-0302.66)	2
964	SPEC-00964	BODY FLANGE (02-0501.E2)	1
1038	SPEC-01038	BARB NUT (02-0604.18)	1
1075	SPEC-01075	GASKET (02-0605.43)	1
1192	SPEC-01192	SHAFT KEY (02-0801.02)	1
1305	SPEC-01305	PISTON DIAPHRAGM BUNA (02-0903.43)	3
1381	SPEC-01381	O-RING (02-1101.27)	6
1382	SPEC-01382	O-RING (02-1101.29)	7
1389	SPEC-01389	O-RING (02-1101.41)	1
1421	SPEC-01421	O-RING (02-1101.88)	1
1434	SPEC-01434	O-RING (02-1101.D1)	1
1490	SPEC-01490	OIL RESERVOIR (02-1203.27)	1
1570	SPEC-01570	PISTON (02-1205.07)	3
1702	SPEC-01702	VALVE ASSEMBLY (02-6006.01)	6
1722	SPEC-01722	HEAD ASSEMBLY (02-6017.13)	3
1740	SPEC-01740	OIL RESERVOIR ASSEMBLY (02-6033.01)	1
1828	SPEC-01828	PISTON & ROD ASSEMBLY (02-6015.45)	3
1843	SPEC-01843	WASHER (02-1403.07)	2
1844	SPEC-01844	WASHER (02-1403.09)	11
1964	SPEC-01964	CONNECTING ROD PIN (02-1502.03)	3
2048	SPEC-02048	SNAP RING (02-1506.07)	1
2051	SPEC-02051	SNAP RING (02-1506.15)	6
2136	SPEC-02136	CONNECTING ROD (02-1519.28)	3
2251	SPEC-02251	PLUG (02-1603.02)	1
2268	SPEC-02268	HEAD PLUG (02-1603.32)	6
2587	SPEC-02587	BOLT (02-1805.20)	6
2589	SPEC-02589	BOLT (02-1805.31)	2
4801	SPEC-04801	O-RING (02-1101.C3)	1
7947	SPEC-07947	HEAD BOLT (02-1804.21)	15
8151	SPEC-08151	MOUNTING RAIL RIGHT SIDE (02-1202.63)	1
8152	SPEC-08152	MOUNTING RAIL LEFT SIDE (02-1202.64)	1
8176	SPEC-08176	CRANKSHAFT (02-0002.B7)	1

** GEAR REDUCTION

112	SPEC-00112	ENGINE GEAR (02-0004.18)	1
137	SPEC-00137	BEARING (02-0006.08)	1
688	SPEC-00688	PUMP GEAR (02-0213.41)	1
756	SPEC-00756	GEAR CASE HALF (02-0228.23)	1
977	SPEC-00977	GASKET (02-0602.05)	1
988	SPEC-00988	GASKET (02-0602.27)	1
1072	SPEC-01072	GASKET (02-0605.09)	1
1400	SPEC-01400	O-RING (02-1101.57)	1
1845	SPEC-01845	WASHER (02-1403.10)	4
1847	SPEC-01847	ALUMINUM GASKET (02-1403.12)	1
1861	SPEC-01861	WASHER (02-1403.39)	1
1886	SPEC-01886	LOCK WASHER (02-1411.03)	1
2034	SPEC-02034	GEAR CASE HALF (02-1505.29)	1
2251	SPEC-02251	OIL PLUG (02-1603.02)	1
2283	UD04-1603.69	OIL SIGHT GAUGE	1
2288	SPEC-02288	VENT CAP (02-1603.81)	1
2481	SPEC-02481	BOLT (02-1804.07)	1
2580	SPEC-02580	BOLT (02-1805.01)	4
2596	SPEC-02596	BOLT OLD STYLE (1805.23) ALLEN HEAD	6
2622	SPEC-02622	BOLT 5/16" X 1" (02-1807.07)	4
2623	SPEC-02623	BOLT 5/16" X 2 1/4" (02-1807.08)	1
5678	SPEC-05678	GUIDE PIN (02-1512.08)	1
5949	SPEC-05949	BOLT (02-1804.72)	6

MISCELLANEOUS PARTS:

NA	GAUGE-600	0-600 PSI LIQUID GAUGE
NA	HOSE-1/2X8-RH	8 FOOT OUTLET HOSE
NA	FITTING-1/2MPIPE	MALE PIPE FITTING
NA	FITTING-1/2-MPX	MALE PIPE SWIVEL
NA	HOSE-1/2-2500XFT	SPECIFY LENGTH OF HOSE
NA	BALLVALVE-1/2	1/2" F X F BALLVALVE
NA	CHECKVALVE-1/2M	1/2" M X M INLINE CHECKVALVE
NA	SPRAY-6815-700-1/2	1/2" PRESSURE RELIEF VALVE
NA	BRIGG-130G32-0022-F1	206 CC FLANGE MOUNT BRIGGS ENGINE
NA	HONDA-GX200UT2-QX2	196 CC FLANGE MOUNT HONDA ENGINE
NA	KING-LARGE	SHIPPING BOX FOR DP(H)-3B
NA	COUPLERBODY-1/2	FEMALE CONNECT TO OUTLET HOSE
NA	COUPLERPLUG-1/2	MALE PUMP OUTLET PIPING
NA	INLET-HOSE-ASSEMBLY	1" X 9' FOOT CLEAR HOSE W/STRAINER
NA	PUMP-DP43-GR	REPLACEMENT PUMP WITH GEAR REDUCTION
NA	DIAPHRAGM-SUCTION	1&1/2" BLACK INLET SUCTION DIAPHRAGM
NA	DIAPHRAGM-CLAMP	1&1/2" INLET SUCTION CLAMP
NA	UD02-8704.29	OUTLET ADAPTER

KITS:

SPEC-DP43-RH1	DIAPHRAGM REPAIR KIT (6) SPEC-01381, O-RING (3) SPEC-01305, BUNA DIAPHRAGM
SPEC-DP43-RH2	VALVE KIT (6) SPEC-01702, VALVE ASSY W/O-RING
SPEC-DP43-RH3	DIAPHRAGM REBUILD KIT (3) SPEC-01305, BUNA DIAPHRAGM (6) SPEC-01702, VALVE ASSY W/O-RING
SPEC-8700.46CK	DIAPHRAGM COMPLETE KIT (3) SPEC-01305, BUNA DIAPHRAGM (6) SPEC-01702, VALVE ASSY W/O-RING (3) SPEC-00808 WASHER (3) SPEC-00240 BOLT

KAPPA-33/43/53 - Exploded View Diagram & Parts List

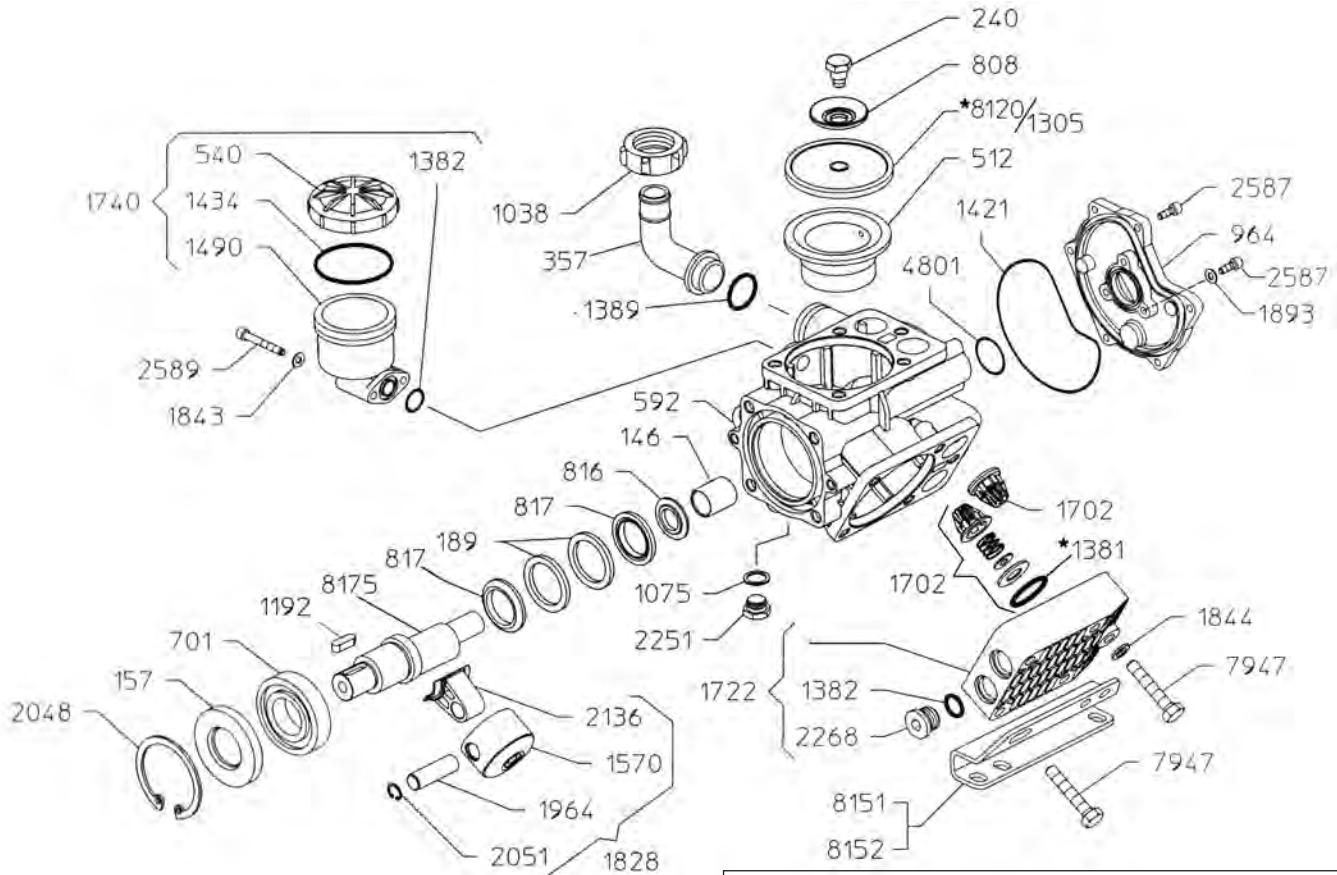

KAPPA-33/43/53 PUMPS

Require 20 oz.
UDOR LUBE
or SAE 30W
Non-detergent Oil

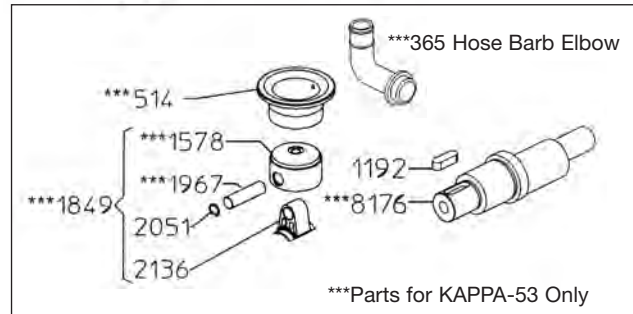

REF#	PART#	DESCRIPTION	QTY	REF#	PART#	DESCRIPTION	QTY
146	02-0006.14	Bearing	1	1740	02-6033.01	Oil Reservoir Assembly	1
157	02-0007.05	Seal	1	1828	02-6015.45	Piston & Rod Assembly (KAPPA-33/43)	3
189	02-0001.11	Retaining Ring	2	1843	02-1403.07	Washer	2
240	02-0102.04	Diaphragm Bolt	3	1844	02-1403.09	Washer	11
357	02-0202.18	Suction Elbow	1	****1849	02-6015.46	Piston & Rod Assembly (KAPPA-53)	3
***365	02-0202.52	Suction Elbow (KAPPA-53)	1	1893	02-1412.03	Washer	3
512	02-0206.42	Piston Sleeve (KAPPA-33)	3	1964	02-1502.03	Connecting Rod Pin (KAPPA-33/43)	3
513	02-0206.41	Piston Sleeve (KAPPA-43)	3	**1967	02-1502.07	Connecting Rod Pin (KAPPA-53)	3
***514	02-0206.43	Piston Sleeve (KAPPA-53)	3	2048	02-1506.07	Snap Ring	1
540	02-0208.98	Oil Reservoir Cap	1	2051	02-1506.15	Snap Ring	6
592	02-0209.73	Crankcase	1	2136	02-1519.28	Connecting Rod (KAPPA-33/43/53)	3
701	02-0214.05	Bearing	1	2251	02-1603.02	Plug	1
808	02-0301.43	Retaining Washer	3	2268	02-1603.32	Head Plug	6
816	02-0301.54	Spacer	1	2587	02-1805.20	Bolt	9
817	02-0302.66	Spacer	2	2589	02-1805.31	Bolt	2
964	02-0501.E2	Body Flange	1	4801	02-1101.C3	O-Ring	1
1038	02-0604.18	Barb Nut	1	7947	02-1804.21	Head Bolt	15
1075	02-0605.43	Gasket	1	*8120	02-0903.50	Piston Diaphragm (DESMOPAN)	3
1192	02-0801.02	Shaft Key	1	8151	02-1202.63	Mounting Rail - Right Side	1
1305	02-0903.43	Piston Diaphragm (BUNA-N) optional	3	8152	02-1202.64	Mounting Rail - Left Side	1
*1381	02-1101.27	O-Ring	6	8175	02-0002.B8	Crankshaft (KAPPA-33)	1
1382	02-1101.29	O-Ring	7	**8176	02-0002.B7	Crankshaft (KAPPA-43/53)	1
1389	02-1101.41	O-Ring	1				
1421	02-1101.88	O-Ring	1				
1434	02-1101.D1	O-Ring	1				
1490	02-1203.27	Oil Reservoir	1				
1570	02-1205.07	Piston (KAPPA-33/43)	3				
***1578	02-1205.18	Piston (KAPPA-53)	3				
1702	02-6006.01	Valve Assembly	6				
1722	02-6017.13	Head Assembly	3				

* Parts included in Diaphragm Repair Kit - Part #8700.45
Diaphragm Repair Kit also available in BUNA-N - Part #8700.46
** Parts for KAPPA-43 only.
*** Parts for KAPPA-53 only.



5071.75 Gear Reduction Parts List and Installation Instructions

For use with:

KAPPA-33
KAPPA-43
KAPPA-53

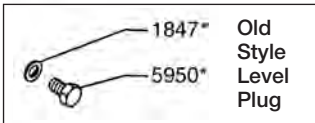
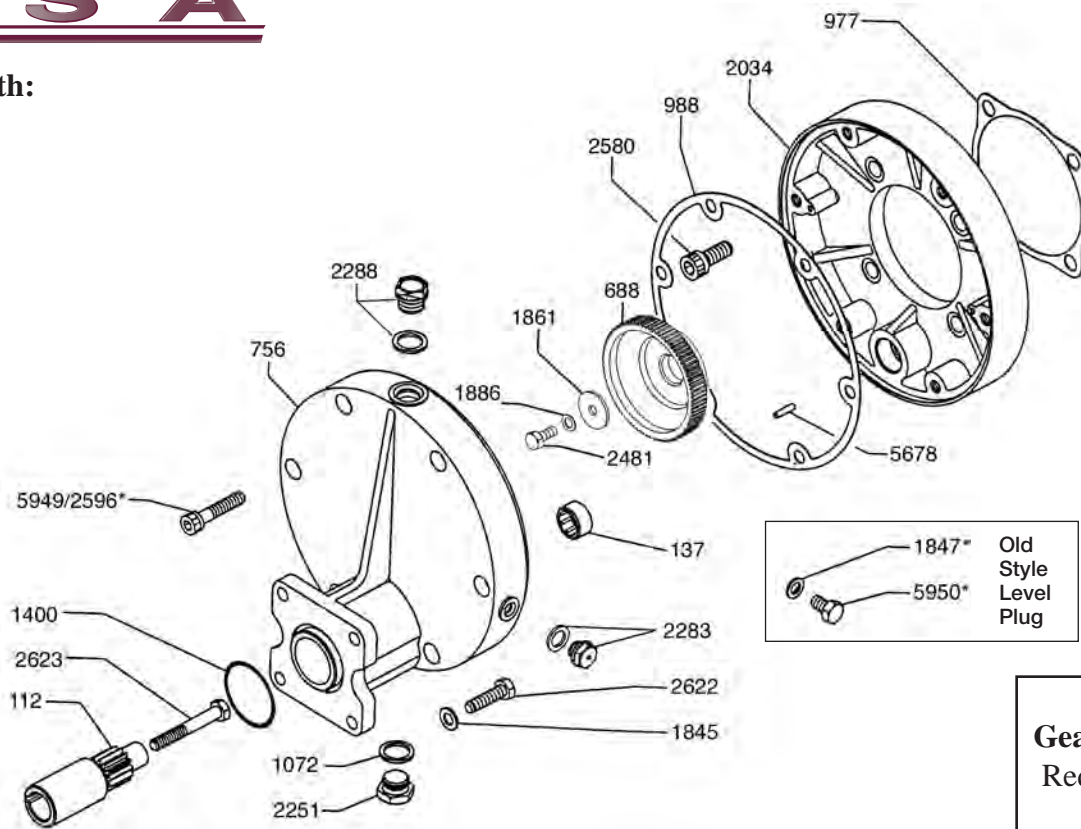

**5071.75
Gear Reduction
Requires 16 oz.
of 90W
Gear Lube**

REF#	PART#	DESCRIPTION	QTY	REF#	PART#	DESCRIPTION	QTY
112	0004.18	Engine Gear	1	2034	1505.29	Gear Case Half	1
137	0006.08	Bearing	1	2251	1603.02	Oil Plug	1
688	0213.41	Pump Gear	1	2283	1603.69	Oil Sight Gauge	1
756	0228.23	Gear Case Half	1	2288	1603.81	Vent Cap	1
977	0602.05	Gasket	1	2481	1804.07	Bolt	1
988	0602.27	Gasket	1	2580	1805.01	Bolt	4
1072	0605.09	Gasket	1	*2596	1805.23	Bolt (old style) Allenhead	6
1400	1101.57	O-Ring	1	2622	1807.07	Bolt - 5/16"x1"	4
1845	1403.10	Washer	4	2623	1807.08	Bolt - 5/16"x2-1/4"	1
*1847	1403.12	Aluminum Gasket (old style)	1	5678	1512.08	Guide Pin	1
1861	1403.39	Washer	1	5949	1804.72	Bolt	6
1886	1411.03	Lock Washer	1	*5950	1804.77	Side Plug (old style)	1

***NOTE: USE BLUE THREADLOCKER 242 OR EQUIVALENT ON ALL BOLTS.**

1. Apply a light coating of anti-seize compound or grease to engine shaft and install 3/16" key, which is supplied with the engine.
2. Install engine gear (Ref #112) on engine shaft and secure with 5/16"x2-1/4" bolt (Ref #2623) provided.
3. Install o-ring (Ref #1400) into groove on gear box and mount assembly onto engine. Secure assembly to engine using the (4)5/16"x1" bolts (Ref #2622) and (4) washers (Ref #1845) provided.
4. Fill gear box with 16 oz. of 90W gear lube to Oil Sight Gauge (Ref #2283).

UDOR U.S.A., INC.

500 Apollo Drive
Lino Lakes, MN 55014
TEL. (651) 785-0666
FAX (800) 732-2670
www.udorusa.com