

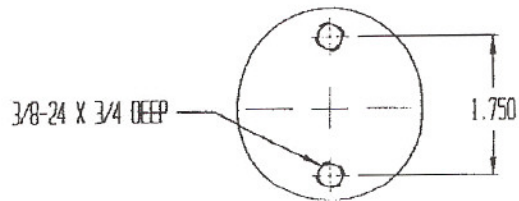

SOUTHERN CALIFORNIA HYDRAULIC ENGINEERING CORPORATION
DESIGNERS AND MANUFACTURERS OF HYDRAULIC & PNEUMATIC EQUIPMENT
1130 COLUMBIA STREET BREA, CALIFORNIA 92821 WWW.SCHYDRAULIC.COM

PUMP ASSEMBLY D6000B20 THRU B35

FORM D6000B20-35 REV 03/08/03

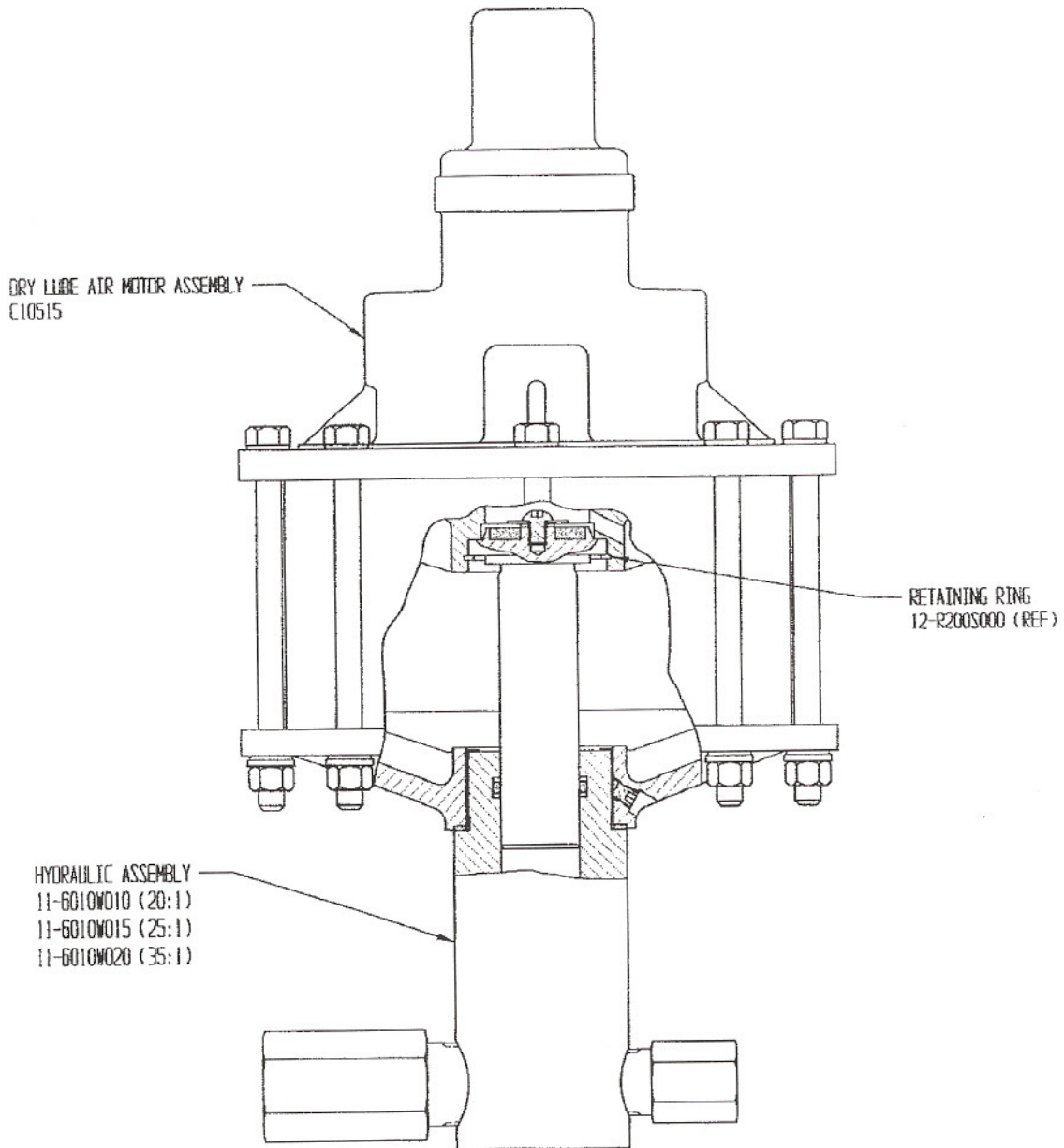

MOUNTING DIMENSIONS



SOUTHERN CALIFORNIA HYDRAULIC ENGINEERING CORPORATION

DESIGNERS AND MANUFACTURERS OF HYDRAULIC & PNEUMATIC EQUIPMENT
1130 COLUMBIA STREET BREA, CALIFORNIA 92821 WWW.SCHYDRAULIC.COM

FORM 11-6010W010-020 REV 09/08/03
(20:1 25:1 35:1)

HYDRAULIC ASSEMBLY 11-6010W010 THRU W020

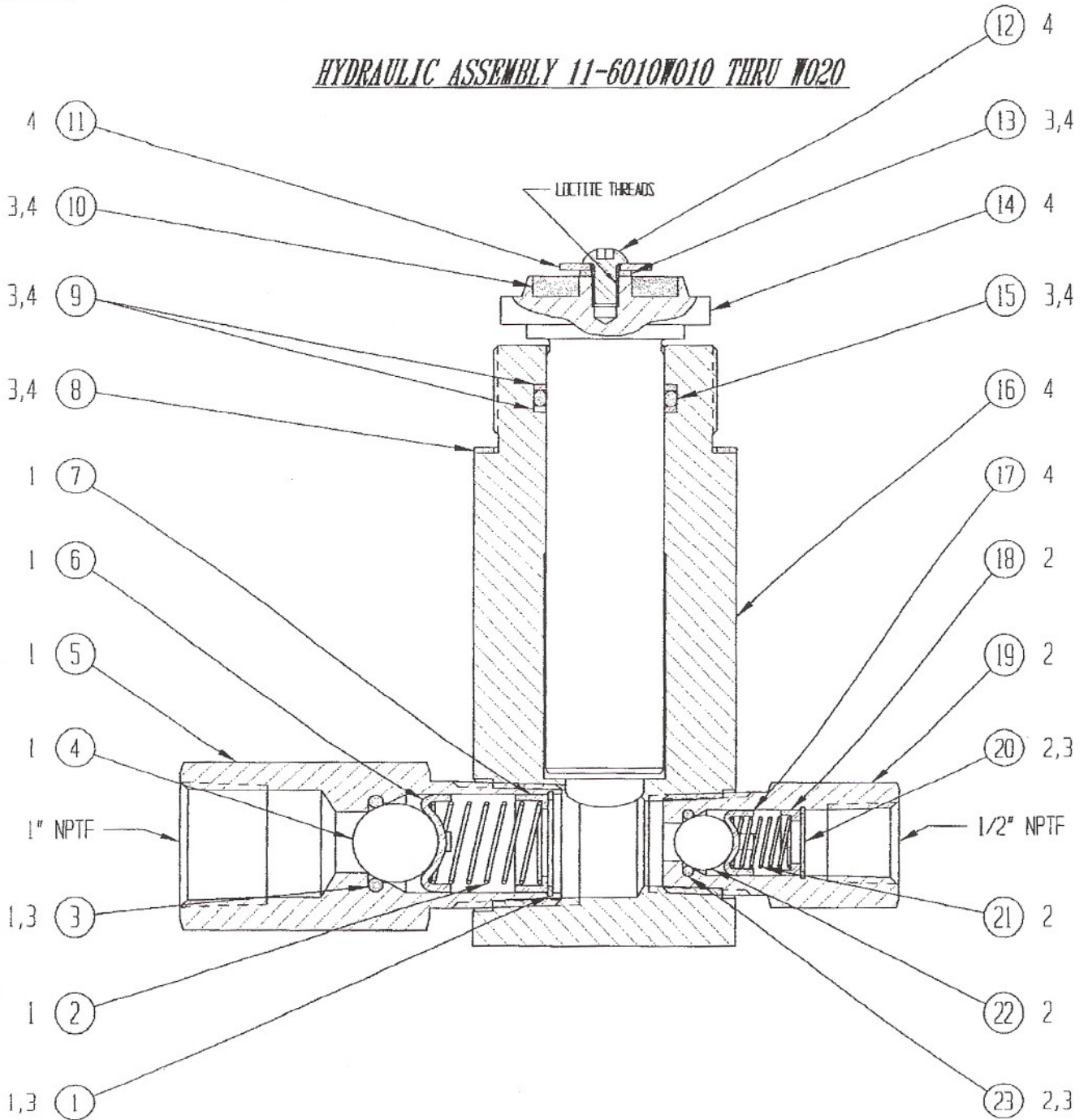

4 INCLUDED IN 11-6011WXXX* PISTON & CYLINDER ASSEMBLY

* REPRESENTS HYDRAULIC ASSEMBLY MODEL NUMBER

3 INCLUDED IN 11-6099NXXX* HYDRAULIC REPAIR KIT

2 INCLUDED IN 11-5023S000 OUTLET CHECK VALVE ASSEMBLY

1 INCLUDED IN 11-5031S000 INLET CHECK VALVE ASSEMBLY



SOUTHERN CALIFORNIA HYDRAULIC ENGINEERING CORPORATION

DESIGNERS AND MANUFACTURERS OF HYDRAULIC & PNEUMATIC EQUIPMENT

1130 COLLETTA STREET BREA, CALIFORNIA 92821 - (714) 257-4800 - FAX (714) 257-4810 WWW.SCHYDRAULIC.COM

BILL OF MATERIALS FILE: 10-550-010.XLS

DRAWING NUMBER & DESCRIPTION: 11-6010W010 THRU W020 HYDRAULIC ASSEMBLY

11-6010 REVISION: 09/12/02

W010 (20:1)	W015 (25:1)	W020 (35:1)	ITEM NO	QTY	PART NO	DESCRIPTION	REFERENCE NO
•	•	•	1	1	P10202-100	RETAINING RING	12-R100S000
•	•	•	2	1	11-5033S000	SPRING	10-450-33
•	•	•	3	1	P11003-210	O-RING	12-6227N015S
•	•	•	4	1	12-0440S812	CHECK BALL	
•	•	•	5	1	11-5035S000	SEAT-INLET	10-450-35
•	•	•	6	1	11-5034S003	BALL GUIDE	10-450-34-3
•	•	•	7	1	11-5032S000	SPRING GUIDE	10-450-32
•	•	•	8	1	11-5028N000	GASKET	10-450-28
•			9	2	P11227-221	BACK UP	12-8774T026
	•		9	2	P11227-219	BACK UP	12-8774T024
		•	9	2	P11227-216	BACK UP	12-8774T021
•	•	•	10	1	11-5051P000	PISTON BUMPER	10-450-51
•	•	•	11	1	12-25N87WF1Z	FENDER WASHER	
•	•	•	12	1	12-25F37SBC45Z	BUTTON HEAD CAP SCREW	
•	•	•	13	1	P10212-025	HELICAL SPRING LOCK WASHER	12-5001C407
•			14	1	11-6008S010 (20:1)	HYDRAULIC PISTON	10-550-8-1
	•		14	1	11-6008S015 (25:1)	HYDRAULIC PISTON	10-550-8-1.50
		•	14	1	11-6008S020 (35:1)	HYDRAULIC PISTON	10-550-8-2
		•	15	1	P11000-221	O-RING	12-6227N026
	•		15	1	P11000-219	O-RING	12-6227N024
		•	15	1	P11000-216	O-RING	12-6227N021
•			16	1	11-6009B010 (20:1)	HYDRAULIC CYLINDER	10-550-9-1
	•		16	1	11-6009B015 (25:1)	HYDRAULIC CYLINDER	10-550-9-1.50
		•	16	1	11-6009B020 (35:1)	HYDRAULIC CYLINDER	10-550-9-2
•	•	•	17	1	11-5034S002	BALL GUIDE	10-450-34-2
•	•	•	18	1	11-5017S000	SPRING GUIDE	10-450-17
•	•	•	19	1	11-5020S000	SEAT-OUTLET	10-450-20
•	•	•	20	1	P10202-068	RETAINING RING	12-R068S000
•	•	•	21	1	11-5013S000	SPRING	10-450-13
•	•	•	22	1	12-0440S562	CHECK BALL	
•	•	•	23	1	P11003-112	O-RING	12-6227N010S

Where Used 10-6000W010-W020
 Pump Assemblies D6000B20-B35



D6 DRY LUBE AIR MOTOR ASSEMBLY C10515

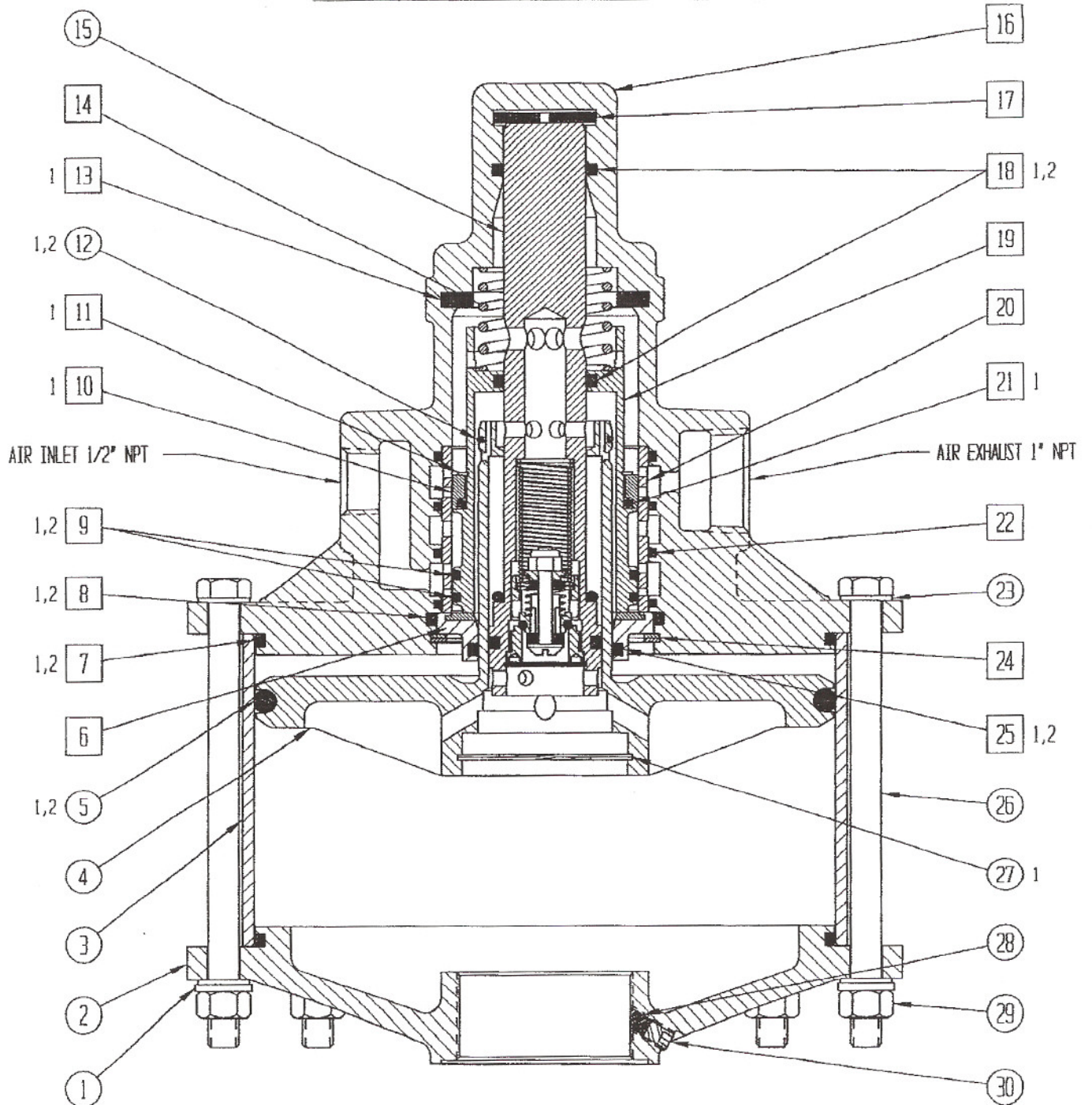

2 INCLUDED IN R10105 AIR MOTOR PACKING SET

1 INCLUDED IN R10104 AIR MOTOR REPAIR KIT

XX INCLUDED IN C10516 HEAD ASSEMBLY



SOUTHERN CALIFORNIA HYDRAULIC ENGINEERING CORPORATION

Designer and Manufacturers of Hydraulic & Pneumatic Equipment

1130 COLUMBIA STREET, BREA, CALIFORNIA 92821 - (714) 257-4800 - FAX (714) 257-4810

BILL OF MATERIALS FILE: C10515.XLS

DRAWING NUMBER & DESCRIPTION: C10515 D6 DRY LUBE AIR MOTOR ASSEMBLY

REVISION: 07/24/06

ITEM NO	QTY	PART NO	DESCRIPTION	REFERENCE NO
1	8	P10212-038	WASHER-LOCK	
2	1	11-6002A000	END	10-550-2
3	1	11-6151P000	CYLINDER-AIR	10-550-151
4	1	11-6025A000	PISTON-AIR	10-550-25
5	1	P11000-439	O-RING	12-6227N066
6	1	11-5047N000	BEARING ASSEMBLY	10-450-47
7	2	P11000-261	O-RING	12-6227N039
8	1	P11000-231	O-RING	12-6227N009
9	2	P11003-137	O-RING	
10	1	D10684	SEAL-DRY	
11	1	P10263-193	RETAINING RING	
12	1	P11000-028	O-RING	12-8775N028
13	1	11-5057P000	BUMPER	10-450-57
14	1	11-5005M002	SPRING	10-450-5-2
15	1	11-6027A000	PILOT VALVE ASSEMBLY	10-450-27
16	1	11-6092A000	HEAD	10-550-92
17	1	11-5012N000	BUMPER	10-450-12
18	2	P11000-214	O-RING	12-6227N019
19	1	D10817	PISTON-APA	
20	1	D10263	SLEEVE-APA	
21	1	P11000-135	O-RING	
22	4	P11000-144	O-RING	12-8775N144
23	16	P10214-038	WASHER-FLAT	
24	1	12-R262S000	RETAINING RING	RRT-262
25	1	P11000-223	O-RING	12-6230N001
26	8	P10230	BOLT-HEX	
27	1	12-R200S000	RETAINING RING	RRT-200
28	1	11-5172N000	PLUG	12-450-172
29	8	12-37CNFH1Z	NUT-HEX	
30	1	P10238	SET SCREW-HEX SOCKET	12-25C313CPSS



PILOT VALVE ASSEMBLY 11-6027A000

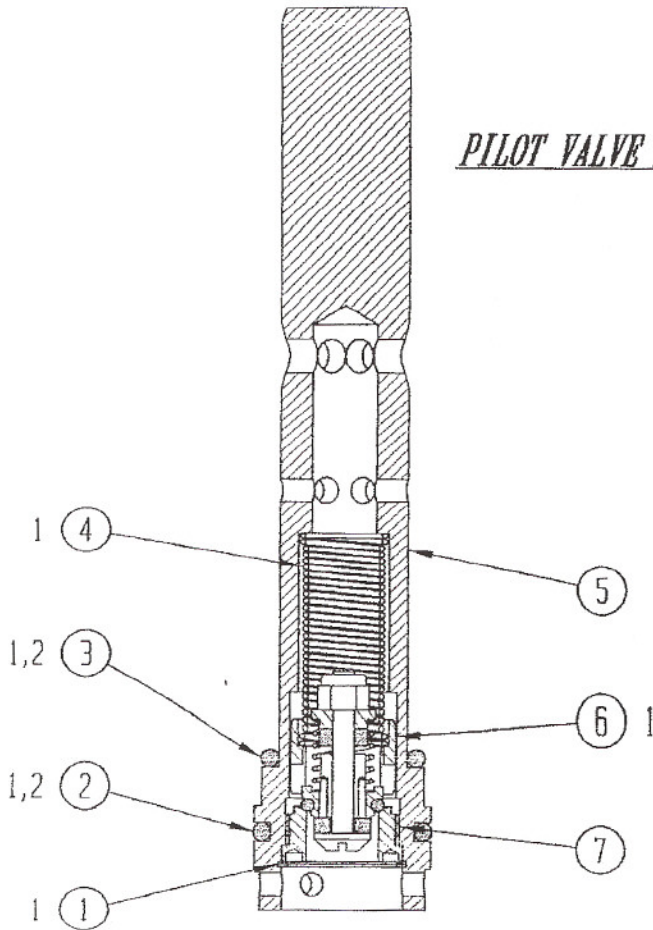

7	1	11-5024A403	SEAT	10-403-24
6	1	11-6032X403	AIR CHECK ASSY	10-403-32-1
5	1	11-6023A000	VALVE BODY	10-550-23
4	1	11-5016M001	SPRING	10-450-16-1
3	1	P11000-214	O-RING	12-6227N019
2	1	P11000-216	O-RING	12-6227N021
1	1	12-R093S000	RETAINING RING	RRT-93
ITEM NO.	QTY	PART NO.	DESCRIPTION	REF NO.

2 INCLUDED IN R10105 AIR MOTOR PACKING SET

1 INCLUDED IN R10104 AIR MOTOR REPAIR KIT

AIR CHECK ASSEMBLY 11-6032X403

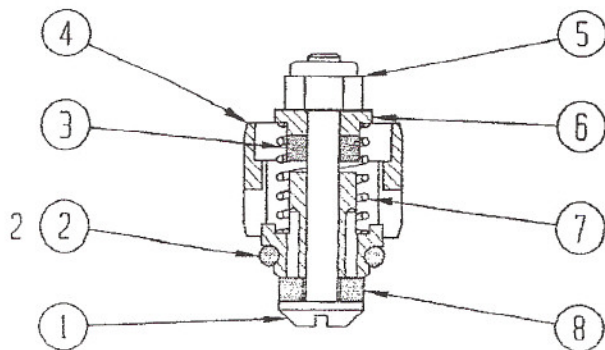

8	1	11-5025M403	WASHER	10-403-25
7	1	11-5015M000	SPRING	10-450-15
6	1	11-5039S000	RETAINER	10-450-39
5	1	12-2104A4D08	NUT	
4	1	11-5171X001	VALVE BODY	10-450-171-1
3	1	11-5043N000	WASHER	10-450-43
2	1	P11000-111	O-RING	12-6227N009
1	1	11-5056A000	SCREW	10-450-56
ITEM NO.	QTY	PART NO.	DESCRIPTION	REF NO.



SOUTHERN CALIFORNIA HYDRAULIC ENGINEERING CORPORATION

Designer and Manufacturers of Hydraulic & Pneumatic Equipment

1130 COLUMBIA STREET, BREA, CALIFORNIA 92821 - WWW.SCHYDRAULIC.COM

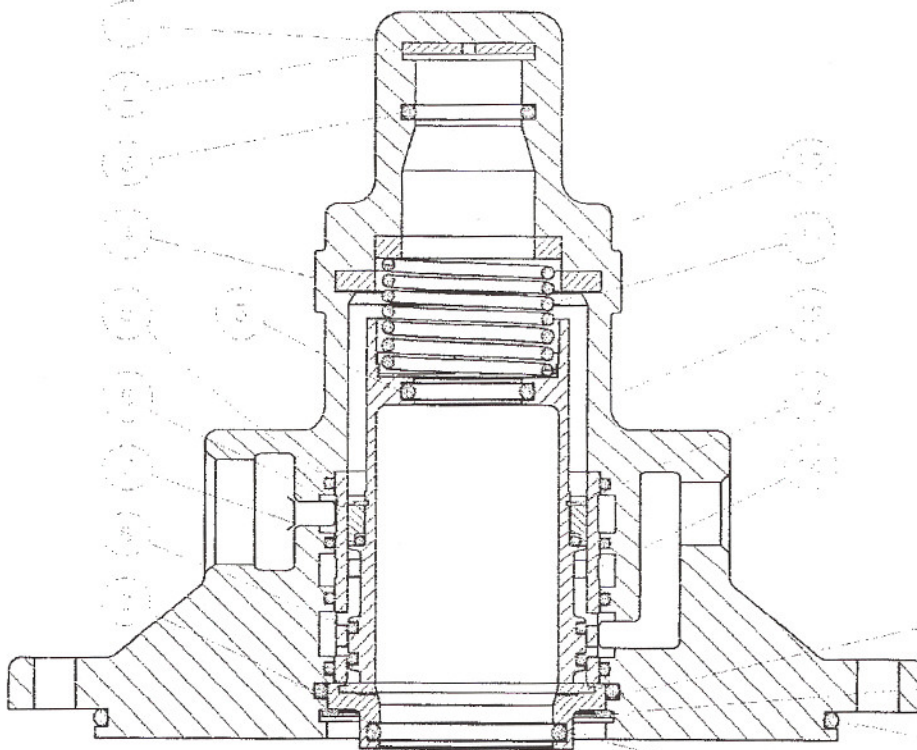

HEAD ASSEMBLY (D6 DRY LUBE) - C10516

(Sheet 1 of 1) REV.14JUN02,D.MACH

HEAD ASSEMBLY - C10516, D6 DRY LUBRICATION					
ITEM	DESCRIPTION	PART NUMBER	QTY	PACKING SET (P10105)	REPAIR KIT (R10104)
1	HEAD	11-80924000	1		
2	SCREWER	11-80121000	1		
3	O-RING	P11000-215	2	X	X
4	SCREWER	11-80514000	1		X
5	O-RING	P11000-114	4		
6	SEAL-D/W	DT0384	1		X
7	O-RING	P11000-135	1	X	X
8	O-RING	P11000-137	2	X	X
9	O-RING	P11000-231	1	X	X
10	SPACER	DT0382	1		
11	SPRING	11-80051002	1		
12	PISTON-ROD	DT0371	1		
13	RETAINING RING	P10363-163	1		X
14	SEAL-SPR	DT0383	1		
15	RETAINING ASSEMBLY	11-80471000	1		
16	RETAINING RING	12-R2575000	1		X
17	O-RING	P11000-257	1	X	X
18	O-RING	P11000-370	1	X	X