

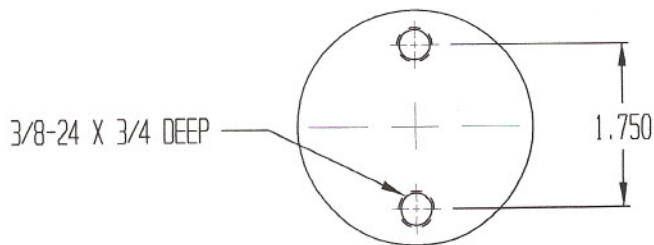

PUMP ASSEMBLY D5000B25 THRU B105

FORM 05000B25-105 REV 06/14/02

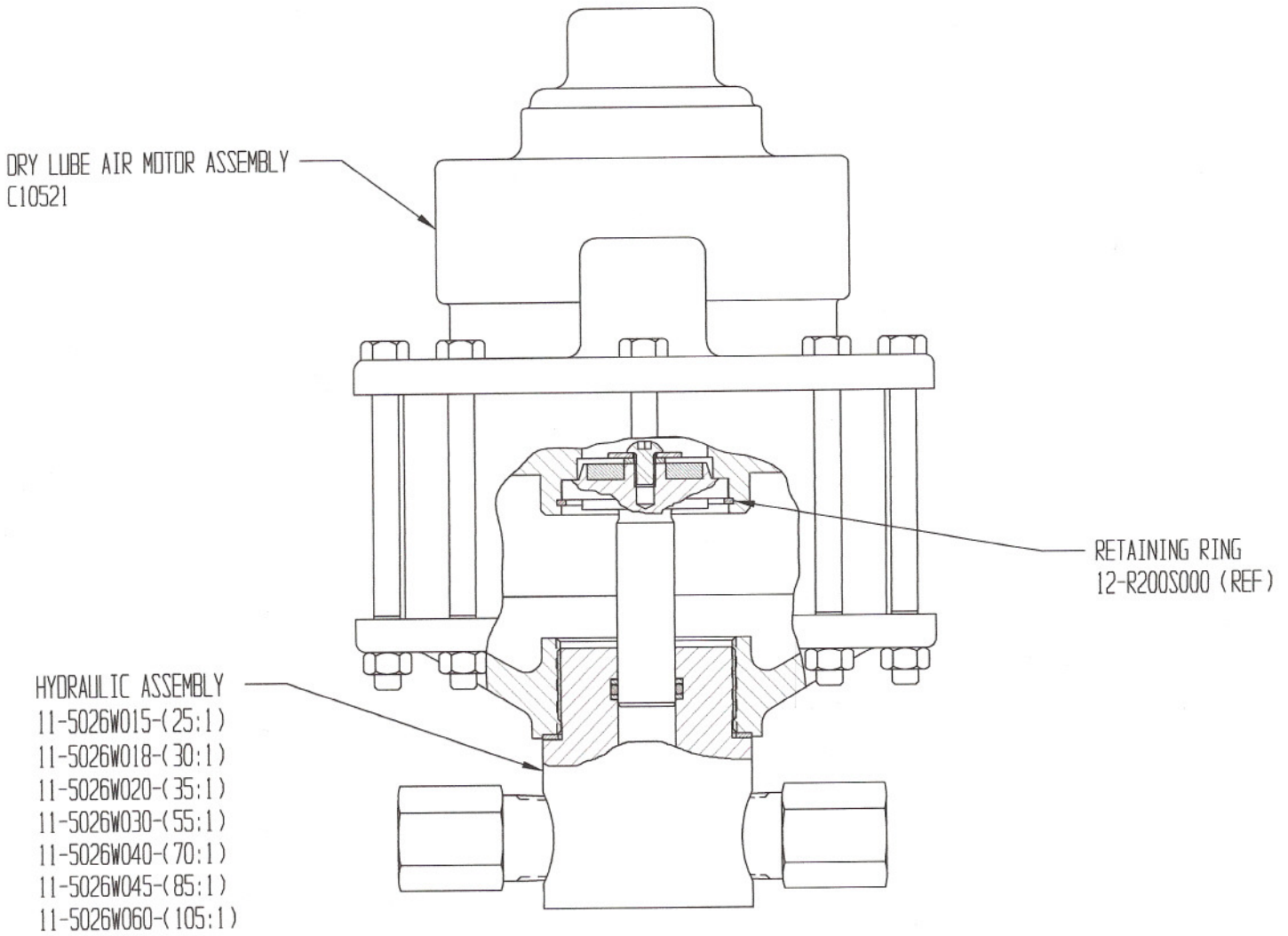

MOUNTING DIMENSIONS



SOUTHERN CALIFORNIA HYDRAULIC ENGINEERING CORPORATION

DESIGNERS AND MANUFACTURERS OF HYDRAULIC & PNEUMATIC EQUIPMENT

1130 COLUMBIA STREET BREA, CALIFORNIA 92821 WWW.SCHYDRAULIC.COM

FORM 11-5026W015-060 REV 07/09/01

25 30 35 55 70 85 105

HYDRAULIC ASSEMBLY 11-5026W015 THRU W060

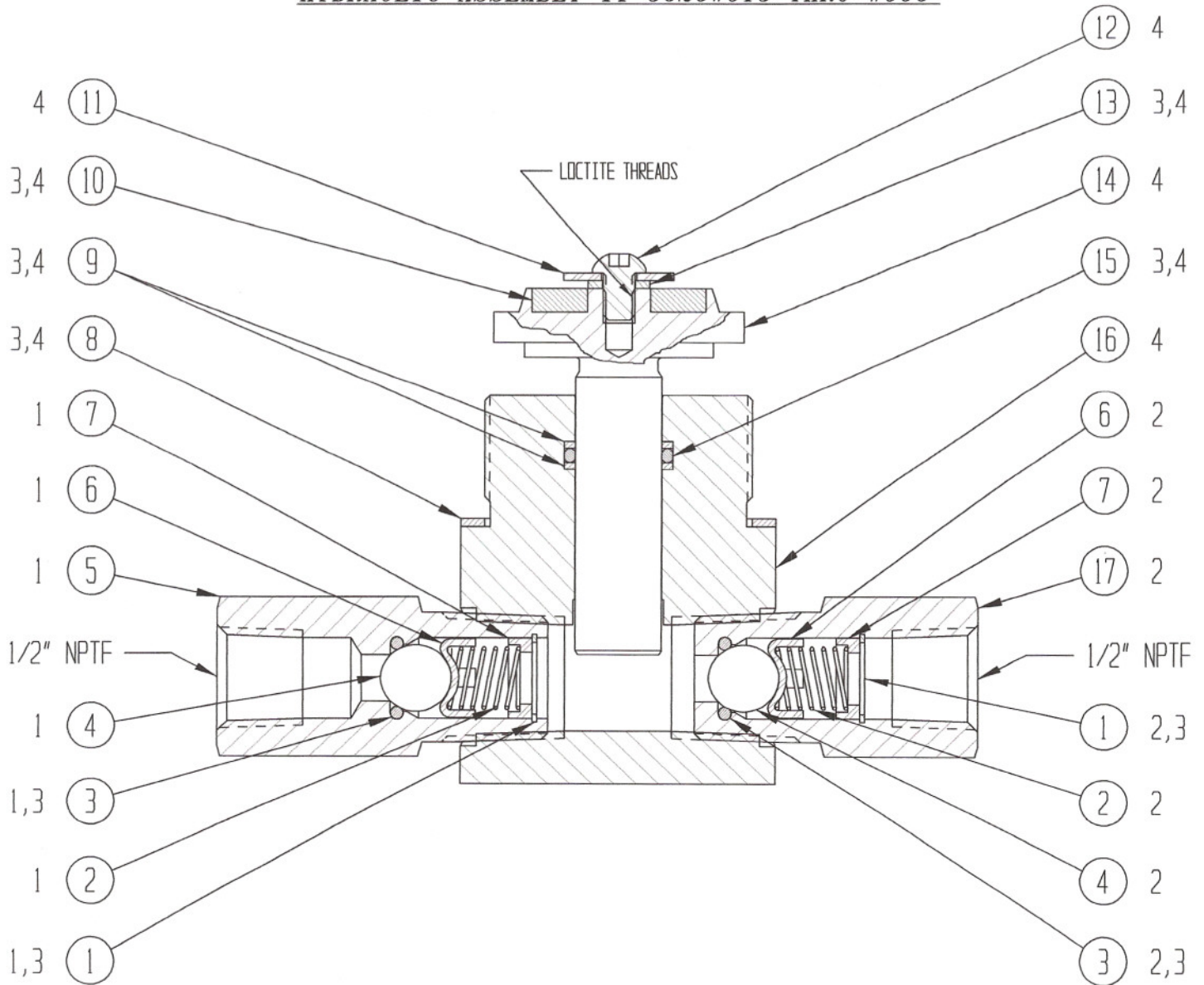

4 INCLUDED IN 11-5027WXXX* PISTON & CYLINDER ASSEMBLY

3 INCLUDED IN 11-5148NXXX* HYDRAULIC REPAIR KIT

2 INCLUDED IN 11-5023S000 OUTLET CHECK VALVE ASSEMBLY

1 INCLUDED IN 11-5024S000 INLET CHECK VALVE ASSEMBLY

* REPRESENTS PUMP ASSEMBLY RATIO NUMBER



SOUTHERN CALIFORNIA HYDRAULIC ENGINEERING CORPORATION

Designer and Manufacturers of Hydraulic & Pneumatic Equipment

1130 COLUMBIA STREET, BREA, CALIFORNIA 92821 - WWW.SCHYDRAULIC.COM

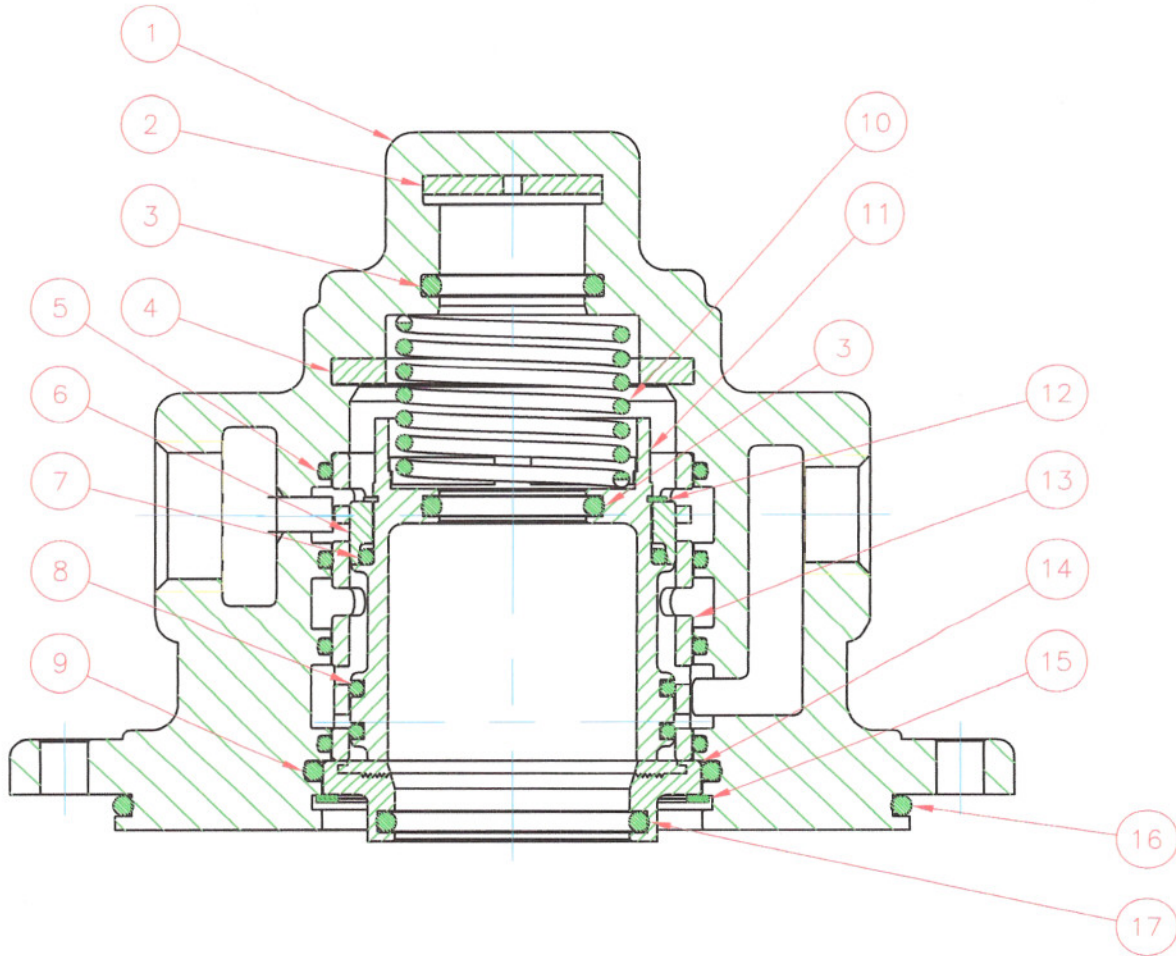

HEAD ASSEMBLY (D5-DRY LUBE) - C10522

(Sheet 1 of 1) REV. A 09/15/04, C. MONTAGUE

ITEM	DESCRIPTION	PART NUMBER	QTY	PACKING SET	REPAIR KIT
1	HEAD	11-5112A000	1		
2	BUMPER	11-5012N000	1		
3	O-RING	P11000-214	2	X	X
4	BUMPER	11-5057P000	1		X
5	O-RING	P11000-144	4		
6	SEAL - DRY	D10684	1		X
7	O-RING	P11000-135	1	X	X
8	O-RING	P11003-137	2	X	X
9	O-RING	P11000-137	2	X	X
10	SPRING	11-5005001	1		
11	PISTON - APA	D01818	1		
12	RETAINING RING	P10263-193	1		X
13	SLEEVE - APA	D10264	1		
14	BEARING ASSEMBLY	11-5047N000	1		
15	RETAINING RING	12-R262S000	1		
16	O-RING	P11000-252	1	X	X
17	O-RING	P11000-223	1	X	X



SOUTHERN CALIFORNIA HYDRAULIC ENGINEERING CORPORATION

Designer and Manufacturers of Hydraulic & Pneumatic Equipment

1130 COLUMBIA STREET, BREA, CALIFORNIA 92821 - (714) 257-4800 - FAX (714) 257-4810

BILL OF MATERIALS FILE: C10521.XLS

DRAWING NUMBER & DESCRIPTION: C10521 D5 DRY LUBE AIR MOTOR ASSEMBLY

REVISION: 07/24/06

ITEM NO	QTY	PART NO	DESCRIPTION	REFERENCE NO
1	8	P10212-031	WASHER-LOCK	
2	1	11-5007A000	END	10-450-7
3	1	11-5181P000	CYLINDER-AIR	10-450-181
4	1	11-5048A000	PISTON-AIR	10-450-48
5	1	P11000-429	O-RING	12-6227N056
6	1	11-5047N000	BEARING ASSEMBLY	10-450-47
7	2	P11000-252	O-RING	12-6230N030
8	1	P11000-231	O-RING	12-6230N009
9	1	P11000-028	O-RING	12-8775N028
10	1	D10684	SEAL-DRY	
11	1	D10264	SLEEVE-APA	
12	1	D10818	PISTON-APA	
13	1	11-5057P000	BUMPER	10-450-57
14	1	11-5005M001	SPRING	10-450-5-1
15	1	11-5060A000	PILOT VALVE ASSEMBLY	10-450-60
16	1	11-5112A000	HEAD	10-450-112
17	1	11-5012N000	BUMPER	10-450-12
18	2	P11000-214	O-RING	12-6227N019
19	1	P10263-193	RETAINING RING	
20	1	P11000-135	O-RING	
21	4	P11000-144	O-RING	12-8775N144
22	2	P11003-137	O-RING	
23	16	P10214-031	WASHER-FLAT	
24	1	12-R262S000	RETAINING RING	RRT-262
25	1	P11000-223	O-RING	12-6230N001
26	8	P10231	BOLT-HEX	
27	1	12-R200S000	RETAINING RING	RRT-200
28	8	12-31CNFH1Z	NUT-HEX	
29	1	11-5172N000	PLUG	10-450-172
30	1	P10238	SET SCREW-HEX SOCKET	12-25C313CPSS



D5 DRY LUBE AIR MOTOR ASSEMBLY C10521

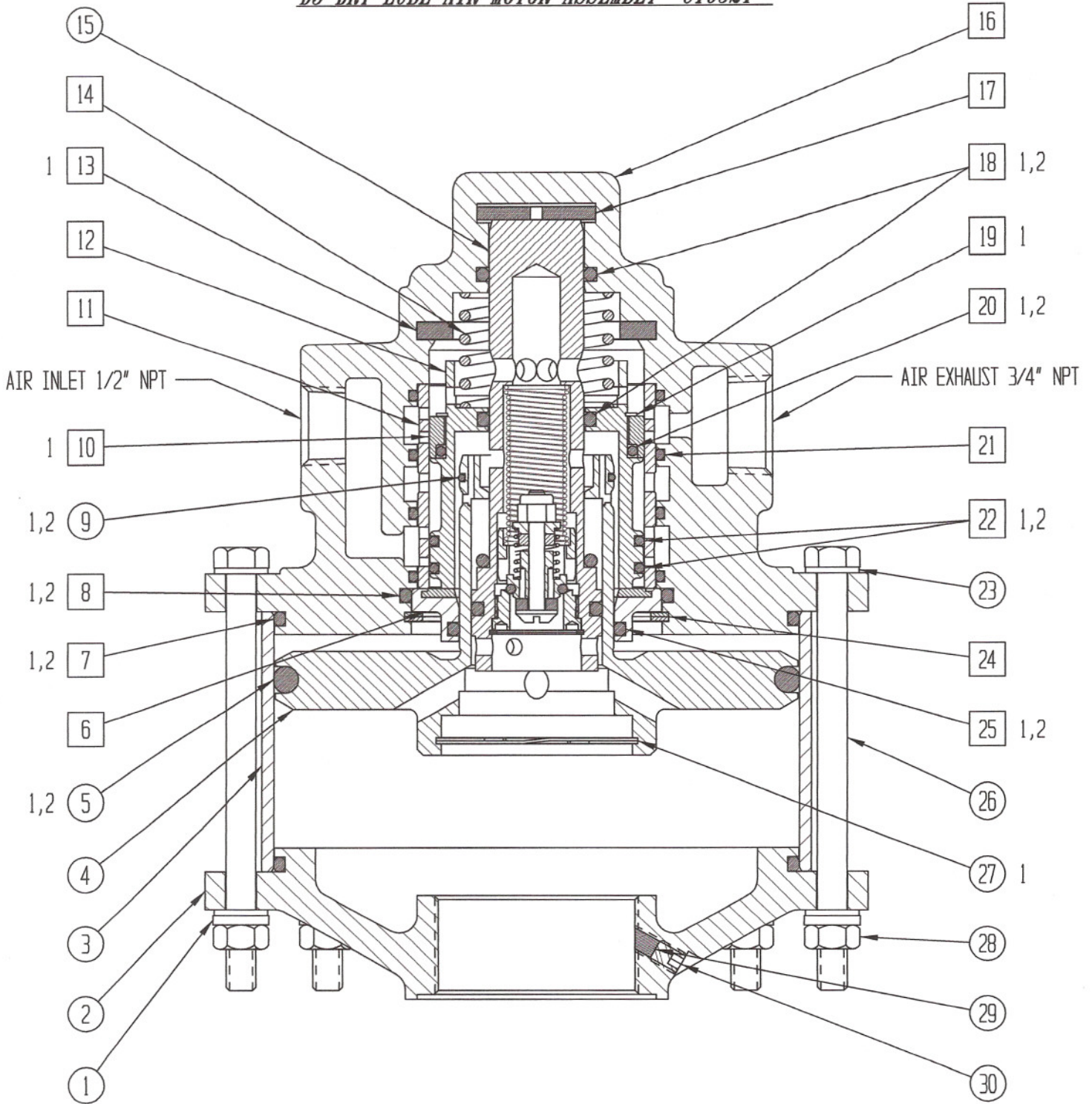

2 INCLUDED IN R10103 AIR MOTOR PACKING SET

1 INCLUDED IN R10102 AIR MOTOR REPAIR KIT

XX INCLUDED IN C10522 HEAD ASSEMBLY



PILOT VALVE ASSEMBLY 11-5060A000

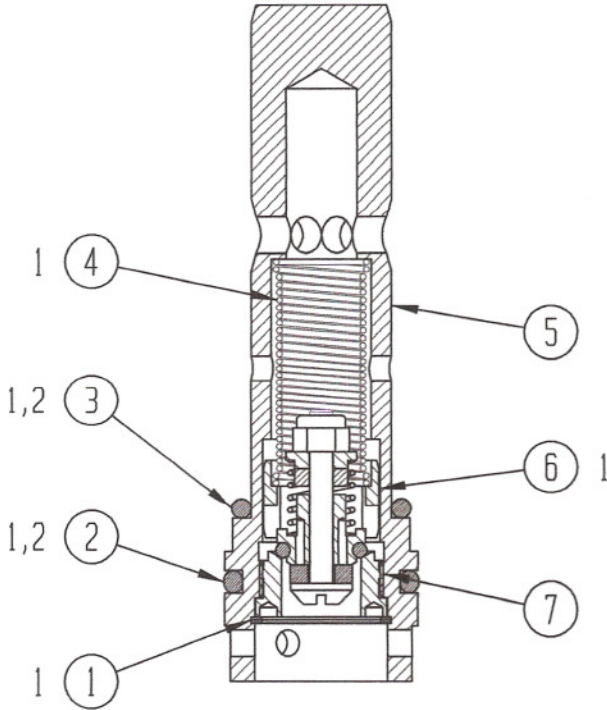

7	1	11-5024A403	SEAT	10-403-24
6	1	11-5032X403	AIR CHECK ASSY	10-403-32
5	1	11-5049A000	VALVE BODY	10-450-49
4	1	11-5016M000	SPRING	10-450-16
3	1	P11000-214	O-RING	12-6227N019
2	1	P11000-216	O-RING	12-6227N021
1	1	12-R093S000	RETAINING RING	RRT-93
ITEM NO.	QTY	PART NO.	DESCRIPTION	REF NO.

2 INCLUDED IN R10103 AIR MOTOR PACKING SET

1 INCLUDED IN R10102 AIR MOTOR REPAIR KIT

AIR CHECK ASSEMBLY 11-5032X403

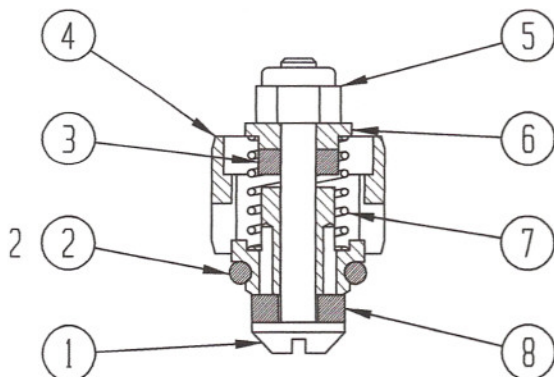

8	1	11-5025N403	WASHER	10-403-25
7	1	11-5015M000	SPRING	10-450-15
6	1	11-5039S000	RETAINER	10-450-39
5	1	12-2104A4D08	NUT	
4	1	11-5171X000	VALVE BODY	10-450-171
3	1	11-5043N000	WASHER	10-450-43
2	1	P11000-111	O-RING	12-6227N009
1	1	11-5056A000	SCREW	10-450-56
ITEM NO.	QTY	PART NO.	DESCRIPTION	REF NO.