

## HYDROSTATIC TEST PUMPS

## Model DE-3C • 6 GPM • 450 PSI

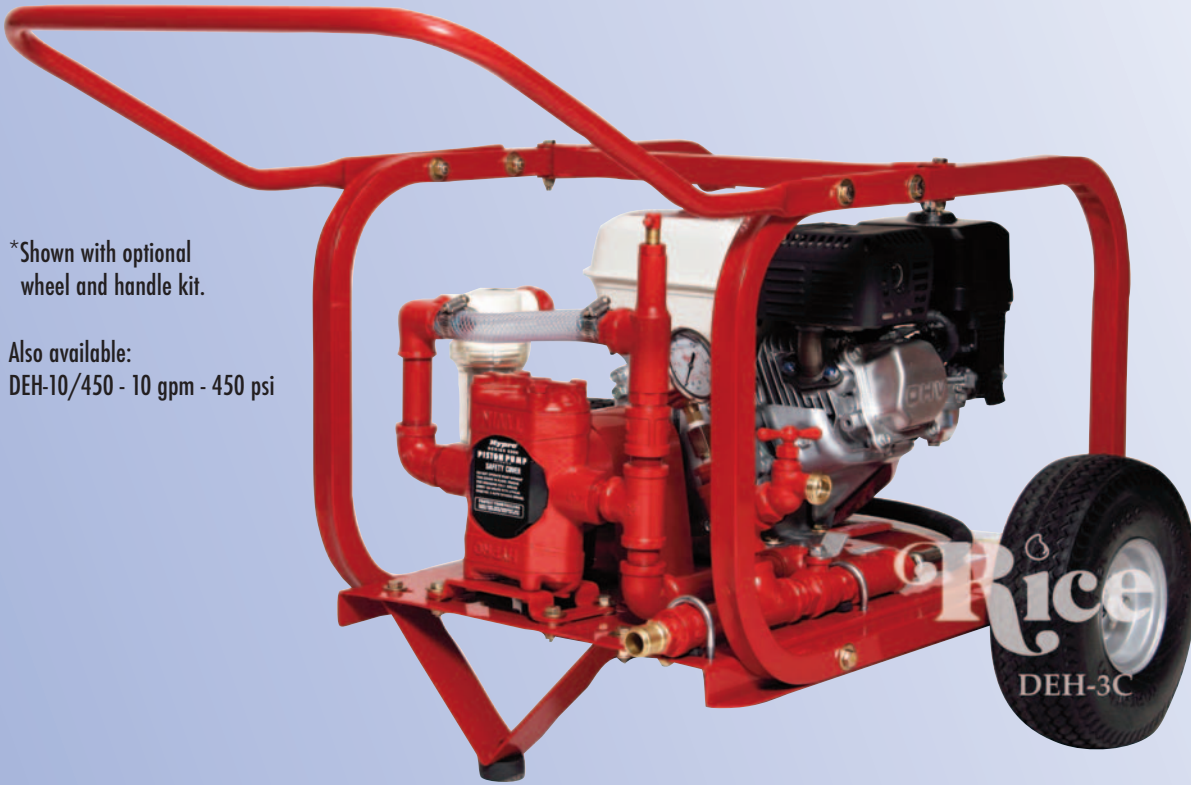

\*Shown with optional wheel and handle kit.

Also available:  
DEH-10/450 - 10 gpm - 450 psi

The DE-3C is a mid volume, medium pressure hydrostatic pump. Designed for testing lines up to 16 inches in diameter. This unit is dependable and simple to run. The pulsation damper hose and liquid-filled stainless steel gauge reduce liability and maintenance costs, while providing the user with precise and accurate readings. The positive displacement twin piston pump, is

manufactured with a cast iron housing and cylinder head, and utilizes stainless steel valves. A pressure regulator with inlet bypass, allows exact setting of test pressure, conserves water, and reduces wear. This unit is available with a Briggs & Stratton or Honda engine option.

- **Automatic Pressure Regulator with Inlet Bypass**
- **Stainless Steel Liquid-Filled Gauge Ensures Accurate Readings, with Less Flutter**
- **Built-in High Pressure Ballvalve & Fittings**
- **In-Line Strainer with Stainless Steel Mesh Filter and Clear Bowl**

**Rice**  
HYDRO INC.

3500 Arrowhead Drive  
Carson City  
Nevada  
89706

web site:  
[www.ricehydro.com](http://www.ricehydro.com)

e-mail:  
[ricehydro@ricehydro.com](mailto:ricehydro@ricehydro.com)

Phone:  
(775) 885-1280

Fax:  
(800) 998-7423

## S P E C I F I C A T I O N S

- **INLET:** 3/4" female hose swivel
- **OUTLET:** 3/4" with Quick Connect Couplings  
High pressure 8 ft. hose  
Pressure regulator adjusting to 450 PSI
- **PUMP:** Twin pistons, positive displacement cast iron housing and cylinder head, stainless steel utilized valves
- **OUTPUT FLOW:** 6 GPM
- **MAX. OUTPUT PRESSURE:** 450 PSI
- **ENGINE:** 160 CC, air-cooled, 4-cycle, Briggs or Honda engine option available
- **SHIPPING DIMENSIONS:** 27" x 22" x 19"
- **SHIPPING WEIGHT:** 107# with pallet 120#

Hydrostatic Test Pumps  Post Hole Diggers

RICE HYDRO, INC.  
MANUFACTURER'S OPERATING INSTRUCTIONS  
DE & RP SERIES MODEL TEST PUMPS

**FOR WARRANTY REGISTRATION CALL: 1-800-245-4777**

 **WARNING:** Operating, servicing and maintaining this equipment can expose you to chemicals including engine exhaust, carbon monoxide and lead, which are known to the State of California to cause cancer and birth defects or other reproductive harm. To minimize exposure, avoid breathing exhaust, do not idle the engine except as necessary, operate and service your equipment in a well-ventilated area and wear gloves or wash your hands frequently when servicing your equipment. For more information go to: [www.p65warnings.ca.gov](http://www.p65warnings.ca.gov)

**REMEMBER THESE CAUTIONS:**

1. Check **ALL** fluid levels prior to operating pump.
2. Use a sound 3/4" or larger supply hose.
3. DO NOT run dry or pump chlorine thru unit.
4. Protect the pump from freezing, FLUSH with anti-freeze.

**CONNECTING THE PUMP:**

1. Check oil level in engine, use 10W30. Unleaded gasoline.
2. Check oil level in the gear reduction, use (90W). Oil should be level with the side drain plug.
3. Connect pressurized water source to the inlet of the pump. It is recommended that the unit be pressure fed. For suction or gravity feed locate water within 8 feet, you may need to prime the pump.
4. Connect the supplied high-pressure outlet hose to the pump and your test environment.

**OPERATING THE PUMP:**

1. Turn the outlet ballvalve to the open position, and start the engine. The engine RPM is preset at the factory, **DO NOT ADJUST**.
2. The pressure regulator has been preset at the factory. **To change this setting you must make this adjustment while the water is flowing freely, and under NO pressure.** To adjust the pressure, first loosen the locknut. Turn the T-handle/Knob clockwise to increase and counterclockwise to decrease the pressure. Place a ballvalve or similar open and close valve at the end of the outlet hose, open and close this valve multiple times as needed, to check pressure setting and re-adjust as necessary. It is also recommended that you open and close the hosebib located under the gauge to bleed excess air from piping and ensure accurate pressure gauge readings. Upon reaching desired pressure setting, tighten locknut and prepare to begin test.
3. With the ballvalve open begin building pressure in the test environment. Be sure to bleed the air from hosebib under gauge at least once during this process. Once test pressure has been reached, **close the ballvalve and shut-off engine.**
4. Once the outlet ballvalve is closed and your test begins, you have now isolated the test pump from the test environment, any loss of pressure is due to leaks or trapped air being compressed in the test environment.

**RECOMMENDED PERIODIC MAINTENANCE PROCEDURE**

1. Change engine(10W30) and gear reduction (90W) after the first 5 hours of operation thereafter every 80 hours of use or every season.
2. **PISTON PUMPS ONLY** -Lubricate cam bearing with grease (wheel bearing grease) every 100 hours of operation or monthly. Use hand operated grease gun to prevent damage to the bearing seal. Grease fitting assembly is located behind the safety cover on the pump.

### Piston Stack Parts Kits

#### Leather Cup Kit No. 3430-0037 (STD)

Consists of two each of the following parts: No. 2220-0013 Piston Cap Screw (Ref. 6A), No. 2270-0012 Washer (Ref. 6B), No. 1720-0030 O-Ring (Ref. 6C), No. 2150-0001 Leather Cup (Ref. 6D), No. 1720-0065 O-Ring (Ref. 6E) and No. 1440-0012 Seal Ring (Ref. 6F).

#### Fabric Cup Kit No. 3430-0039

Same as Leather Cup Kit except with two No. 2150-0012 Fabric Cups.

#### Rubber Cup Kit No. 3430-0189

Same as Leather Cup Kit except with two No. 2150-0042 Rubber Cups.

### Crankshaft Assemblies

#### Sub-Assemblies

Include Grease Fitting (Ref. 12), Crankshaft with cam bearing (Ref. 13 or 14) and Crankpin Retainer (Ref. 16).

#### Complete Assemblies

Include Sub-Assembly components plus Retaining Rings (Ref. 15), slinger rings (Ref. 20) and Bearing (Ref. 21).

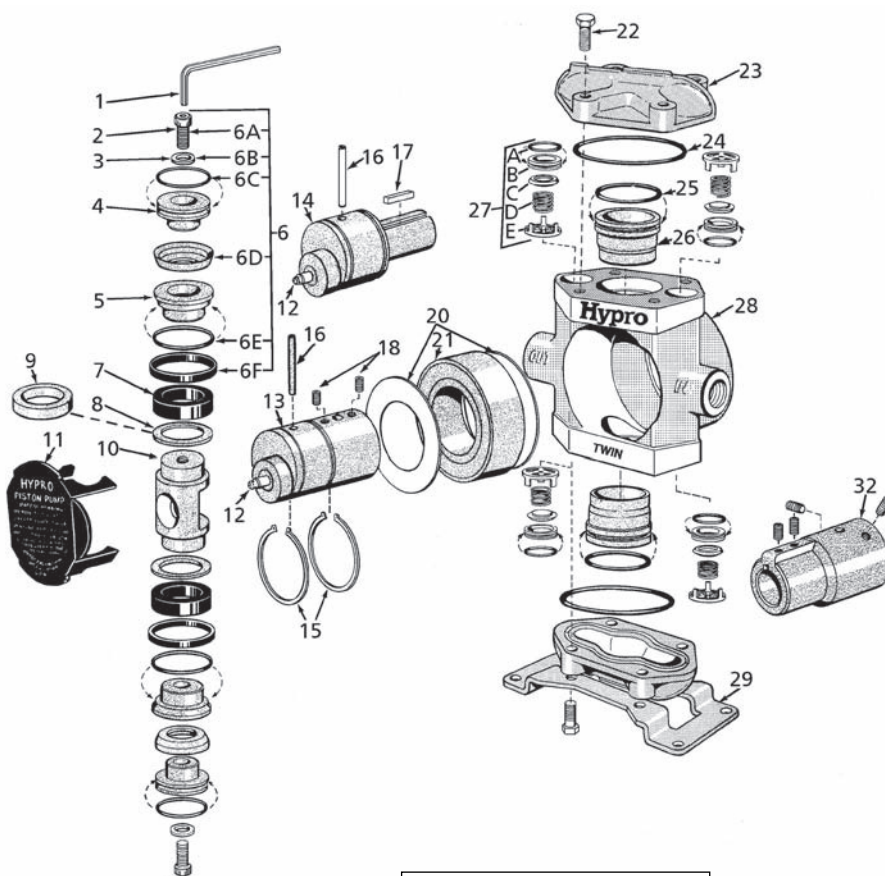

**NOTE:** When ordering parts, give **quantity, part number, description, and complete model number.** Reference numbers are used **ONLY** to identify parts in the drawing and are **NOT** to be used as order numbers.

Sub-Assembly PART NO.	Complete Assembly PART NO.	Pump Model Number
<b>with 1-3/8" Hollow PTO Shaft (Ref. 13)</b>		
5503-5206	5501-5206	5206C-H
5503-5210	5501-5210	5210C-H
<b>with 1" Solid Shaft (Ref. 14)</b>		
5003-5206	5001-5206	5206C
5003-5210	5001-5210	5210C

Ref. No.	Qty. Req'd.	Part No.	Description
1	1	3020-0008	Allen Wrench (Optional)
2	2	2220-0013	Piston Cap Screw
3	2	2270-0012	Washer
4	2	1830-0039	Piston Cup Spreader
5	2	1410-0054	Cup Backing Plate
6	1	3430-0037	Piston Stack Parts Kit with Leather Cups (Standard)
6	1	3430-0039	Piston Stack Parts Kit with Fabric Cups (Models 5200-F)
6	1	3430-0189	Piston Stack Parts Kit with Buna-N Cups (Models 5200-R)
7	2	1440-0005	Piston Guide
8	2	1410-0018	Support Ring For 5210 Models Only
9	2	1410-0020	Support Ring For 5206 Models Only
10	1	0503-5200	Connecting Rod
11	1	0602-5200	Safety Cover
12	1	2405-0006	Grease Fitting Assembly
13	1	See Listing	Crankshaft (Solid Shaft Models)
14	1	See Listing	Crankshaft (Hollow Shaft Models)
15	2	1810-0001	Retainer Ring
16	1	1600-0013	Crankpin Retainer

Ref. No.	Qty. Req'd.	Part No.	Description
17	1	1610-0005	Key (Solid Shaft Models)
18	2	2230-0003	Set Screw
20	2	1410-0006	Slinger Ring
21	1	2005-0002	Main Bearing
22	8	2210-0062	Cylinder Head Bolt
23	2	0203-5200CB	Cylinder Head
24	2	1720-0028	O-Ring – for cylinder head
25	2	1720-0019	O-Ring – for cylinder sleeve
26	2	3550-0007	Cylinder Sleeve
27	4	3400-0038	Valve Assembly—Consists of: O-ring (Ref. A), Valve Seat (Ref. B), Valve Poppet (Ref. C), Valve Spring (Ref. D) and Valve Spring Retainer (Ref. E)
28	1	0100-5200C	Body
29	1	1510-0024	Base
32	1	1320-0081	Adapter-Adapts 1" solid shaft to 1-3/8" 6-spline PTO hollow shaft. (Includes set screws.)

PARTS BREAKDOWN FOR MODEL DE-SERIES  
RICE HYDRO INC.

PUMP PARTS:

REF#	PART NUMBER..	DESCRIPTION..	QTY REQ'D
2	HYPRO-2220-0013	PISTON CAP SCREW	2
3	HYPRO-2270-0012	WASHER	2
4	HYPRO-1830-0039	PISTON CUP SPREADER	2
5	HYPRO-1410-0054	CUP BACKING PLATE	2
7	HYPRO-1440-0005	PISTON GUIDE	2
8	HYPRO-1410-0018	SUPPORT RING (FOR 5210 ONLY)	2
9	HYPRO-1410-0020	SUPPORT RING (FOR 5206 ONLY)	2
10	HYPRO-0503-5200	CONNECTING ROD	1
11	HYPRO-0602-5200	SAFETY COVER	1
12	HYPRO-2405-0006A	GREASE FITTING ASSEMBLY	1
14	HYPRO-5003-5206	CRANKSHAFT SUB-ASSY (FOR 5206)	1
14	HYPRO-5001-5206	CRANKSHAFT COMPLETE ASSY (FOR 5206)	1
14	HYPRO-5003-5210	CRANKSHAFT SUB-ASSY (FOR 5210)	1
14	HYPRO-5001-5210	CRANKSHAFT COMPLETE ASSY (FOR 5210)	1
15	HYPRO-1810-0001	RETAINER RING	2
16	HYPRO-1600-0013	CRANKPIN RETAINER	1
17	HYPRO-1610-0005	KEY FOR SOLID SHAFT	1
20	HYPRO-1410-0006	SLINGER RING	2
21	HYPRO-2005-0006	MAIN BEARING	1
22	HYPRO-2210-0062	CYLINDER HEAD BOLT	8
23	HYPRO-0203-5200CB	CYLINDER HEAD	2
24	HYPRO-1720-0028	O-RING FOR CYLINDER HEAD	2
25	HYPRO-1720-0019	O-RING FOR CYLINDER SLEEVE	2
26	HYPRO-3550-0007	CYLINDER SLEEVE	2
27	HYPRO-3400-0038	VALVE ASSEMBLY	4
28	HYPRO-0100-5200C	PUMP BODY 5200 SERIES	1
29	HYPRO-1510-0024	PUMP BASE	1

MISCELLANEOUS PARTS:

NA	BRIGG-12S452-0049-F8	5.5 HP 206 CC ENGINE W/GR	1
NA	HONDA-GX160UT2-HX2	5.5 HP 163 CC ENGINE W/GR	1
NA	BALLVALVE-3/4	3/4" BALLVALVE	1
NA	GAUGE-600	0-600 PSI LIQUID GAUGE	1
NA	GAUGE-SNUBBER-1/4	VIBRATION SNUBBER	1
NA	CENTERDISK-5206	URETHANE SPIDER 5206 (ORANGE)	1
NA	CENTERDISK-5210	HYTREL SPIDER 5210 (WHITE)	1
NA	COUPLING-LVJ-3/4	3/4" COUPLING (ENGINE SIDE)	1
NA	COUPLING-LVJ-ENG-1"	1" COUPLING (PUMP SIDE)	1
NA	LINESTRAINER-3/4	COMPLETE LINESTRAINER ASSEMBLY	1
NA	HYPRO-5206C-FL	TWIN PISTON 6 GPM 450 PSI	1
NA	HYPRO-5210C-FL	TWIN PISTON 10 GPM 450 PSI	1
NA	SPRAY-6815-700-3/4	PRESSURE REGULATOR	1
NA	SWIVEL-3/4	HOSE SWIVEL INLET	1
NA	HOSESCREEN&WASHER	INLET HOSE SCREEN	1
NA	LABEL-KIT-DE	INSTRUCTION AND CAUTION STICKERS	1
NA	HOSE-3/4X8-RH	8' FOOT OUTLET HOSE - STANDARD	1
NA	COUPLERBODY-3/4	FEMALE PUMP OUTLET - HOSE	1
NA	COUPLERPLUG-3/4	MALE PUMP OUTLET - PIPING	1
NA	HOSE-3/4-1250XFT	SPECIFY LENGTH OF HOSE	
NA	FITTING-3/4-MPIPE	FITTING FOR HOSE - RIGID	1
NA	FITTING-3/4-MPX	FITTING FOR HOSE - SWIVEL	1

KITS:

\*KITS ARE ALL INCLUSIVE\*

KIT	HYPRO-3430-0037	PISTON STACK PARTS KIT - REF #6 LEATHER CUPS	1
KIT	HYPRO-3430-0039	PISTON STACK PARTS KIT - REF #6 FABRIC CUPS	1
KIT	PULSE-HOSE-KIT	PULSATION DAMPENER HOSE	1
KIT	SPRAY-AB6815-700	REGULATOR REPAIR KIT	1