



# Diaphragm Series

## Test Pumps

The DP series is the most versatile, reliable, and sought-after Hydrostatic Test Pump on the market today. Designed as a medium pressure, large volume test pump, with positive displacement for optimum speed and performance. Models in this series offer “gallon per minute” flow rates from 11 to 56 (GPM); with “pounds per square inch” testing capabilities from 50 to 600 (PSI). These Hydrostatic Test Pumps will easily fill and test almost any size line you may encounter. “Built to Suit” special order and custom options are available to fit your specific testing needs.



### DPH-3B 11 GPM up to 550 PSI

- Triple Diaphragm Pump
- Exceptionally Smooth Operation
- Can Handle up to a 10% Chlorine solution
- No Aerated Lines - Quicker Pressurization
- Adjustable Pressure Regulator with Inlet Bypass
- Stainless Steel Liquid Filled Gauge – Ensures Accurate Reading with less Flutter
- Optional 9-foot Inlet Hose Assembly with camlock coupling and stainless-steel mesh filter
- Optional Wheel and Handle Kit
- Optional Pressure feed tank



### DPH-8 32 GPM up to 300 PSI

- Custom Model - DPH-6 19 GPM up to 600 PSI
- Triple Diaphragm Pump
- Exceptionally smooth operation
- Can Handle up to a 10% Chlorine solution
- No Aerated Lines - Quicker Pressurization
- Adjustable Pressure Regulator with Inlet Bypass
- Stainless Steel Liquid Filled Gauge – Ensures Accurate Reading with less Flutter
- Optional 9-foot Inlet Hose Assembly with camlock coupling and stainless-steel mesh filter
- Optional Wheel and Handle Kit
- Optional Pressure feed tank



### **DPH-56/250 56 GPM up to 250 PSI**

- Six Diaphragm Pump
- Exceptionally Smooth Operation
- Can Handle up to a 10% Chlorine solution
- No Aerated Lines - Quicker Pressurization
- Adjustable Pressure Regulator with Inlet Bypass
- Stainless Steel Liquid Filled Gauge – Ensures Accurate Reading with less Flutter
- Optional Wheel and Handle Kit

## **Accessories**

### **Wheel and Handle Kits**



- Portable "Back Saver" - the wheel and handle kit instantly makes your test pump truly portable and easy to maneuver, saving you time, labor, maintenance, and repair
- "NO FLAT" tires are made of polyurethane foam with open and closed air cells, forming a tire two times stronger than rubber, yet soft enough to provide bounce and absorb vibration



### **Pressured Tanks**

- DPH-6, 40 Gallon Tank
- DPH-8, 40 Gallon Tank
- DPH-3B, 20 Gallon Tank
- Fabricated for pressure feeding
- Saves time, labor, repair, and maintenance costs, by virtually eliminating the rupture/damage of diaphragms caused by excessive inlet pressure
- Heavy duty polypropylene tank provides easy access for chemical treatment of water lines and test environment, eliminating the need for a 55-gallon water drum



### **Inlet Hose Assemblies**

- Inlet Hose assembly, 9-foot with camlock coupler
- Protects the pump from debris
- Equipped with a fine mesh stainless steel strainer
- Feeding from a 55-gallon water drum or other source
- Available on most models

RICE HYDRO, INC.  
MANUFACTURER'S OPERATING INSTRUCTIONS  
TEST PUMP MODEL DP-Series (3/6/8/56-250)  
**FOR WARRANTY REGISTRATION CALL: 1-800-245-4777**

TO ATTACH FLOW METER - CALL FACTORY FOR INSTRUCTIONS

 **WARNING:** Operating, servicing and maintaining this equipment can expose you to chemicals including engine exhaust, carbon monoxide and lead, which are known to the State of California to cause cancer and birth defects or other reproductive harm. To minimize exposure, avoid breathing exhaust, do not idle the engine except as necessary, operate and service your equipment in a well-ventilated area and wear gloves or wash your hands frequently when servicing your equipment. For more information go to: [www.p65warnings.ca.gov](http://www.p65warnings.ca.gov)

**CAUTIONS:**

1. Check **ALL** fluid levels prior to operating the unit.
2. Use the inlet hose that was supplied, or a similar type suction hose the same size as the inlet piping.
3. NEVER connect the inlet of the pump directly to a pressurized water source.
4. Protect the pump from freezing, FLUSH with anti-freeze after each use.

**CONNECTING THE PUMP:**

1. Check pump oil thru reservoir sight glass, half-way to the top is full. Use 30w non-detergent oil.
2. Check oil level in engine crankcase, use (10W30) as needed.
3. Check oil level in the gear reduction, use (90W) as needed. Oil should be level with the side plugs.
4. On units 6/8 accumulator head is equipped with a valve stem to adjust air pressure of the accumulator diaphragm. Set between 90-120 psi. This is a small cavity and will take very little air to do so.
5. Connect inlet hose assembly provided. The pump MUST be either suction fed (such as out of a barrel), or gravity fed (from a water truck).

**A PRESSURIZED LINE CANNOT BE USED TO SUPPLY WATER TO THE PUMP.**

Never connect the unit to a water source such as a standpipe, hose bib tap water faucet, etc. ... **unless a PRESSURED FEED Tank accessory is added.** The source of water should be within 8-10 ft. maximum.

6. Connect high pressure outlet hose supplied by manufacturer with quick connects or direct fitting as provided. If using a hose other than that supplied by manufacturer, PSI and burst rate must meet or exceed manufacturer's requirements.

### **OPERATING THE PUMP:**

1. Turn the outlet ballvalve to the open position, and start the engine. The engine RPM is preset at the factory, **DO NOT ADJUST!**
2. The pressure regulator has been preset at the factory. **To change this setting you must make this adjustment while the water is flowing freely, and under NO pressure.** To adjust the pressure, first loosen the locknut. Turn the T-handle/Knob clockwise to increase and counterclockwise to decrease the pressure. Place a ballvalve or similar open and close valve at the end of the outlet hose, open and close this valve multiple times as needed, to check pressure setting and re-adjust as necessary. It is also recommended that you open and close the hosebib located under the gauge to bleed excess air from piping and ensure accurate pressure gauge readings. Upon reaching desired pressure setting, tighten locknut and prepare to begin test.
3. With the ballvalve open begin building pressure in the test environment. Be sure to bleed the air from hosebib under gauge at least once during this process. Once test pressure has been reached, **close the ballvalve and shut-off engine.** An inlet checkvalve prevents water pressure from bleeding back into the pump.
4. Once the outlet ballvalve is closed and your test begins, you have now isolated the test pump from the test environment, any loss of pressure is due to leaks or trapped air being compressed in the test environment.

### **REMEMBER THESE CAUTIONS:**

1. Check all fluid levels prior to operating pump.
2. Use the inlet hose that was supplied, or use a suction hose the same size as the inlet piping.
3. NEVER connect the inlet of the pump directly to a pressurized source.
4. Protect the pump from freezing, FLUSH with anti-freeze

### **RECOMMENDED PERIODIC MAINTENANCE PROCEDURE**

1. Change engine oil after the first 80 hours of operation thereafter every 250 hours of use or every season.
2. Change the oil in the pump body after the first 50 hours of operation thereafter every 250 hours.

## **TROUBLE SHOOTING FOR DP-SERIES HYDROSTATIC TEST PUMP**

### **IF PUMP FAILS TO BUILD PRESSURE:**

1. Look for leaks in water supply hose and connections.
2. Supply hose is too small. Filter may be clogged.
3. Supply hose may be kinked or collapsed. Maximum of 9 feet.
4. The Pump may be sucking air. Small holes in the supply hose are hard to find since the air is drawn inward, therefore no bubbles would be present. Replace the supply hose. Possible loose piping or connections.
5. T-handle/Knob on pressure regulator may be set incorrectly.
6. Faulty pressure gauge, replace.
7. Pump is running too slow. Advance throttle on engine to between 3400-3600 RPM, but no higher.
8. Pipeline being tested may have leaks, or an open valve. Isolate the pump and do a self-test, by placing a ballvalve at the end of the outlet hose.
9. Foreign material may be lodged in a valve, preventing the valve from seating properly. Remove cylinder head. Remove valve assemblies, clean and replace.
10. Airlock. With pump running, open and close bleed valves several times to remove the air that may be trapped in the piping.
11. Diaphragms may be ruptured, oil in crankcase will be milky white. Drain oil from pump and install new diaphragms.
12. No air in accumulator head on models 6/8, reset between 90-120 psi.

# APS31 / 41

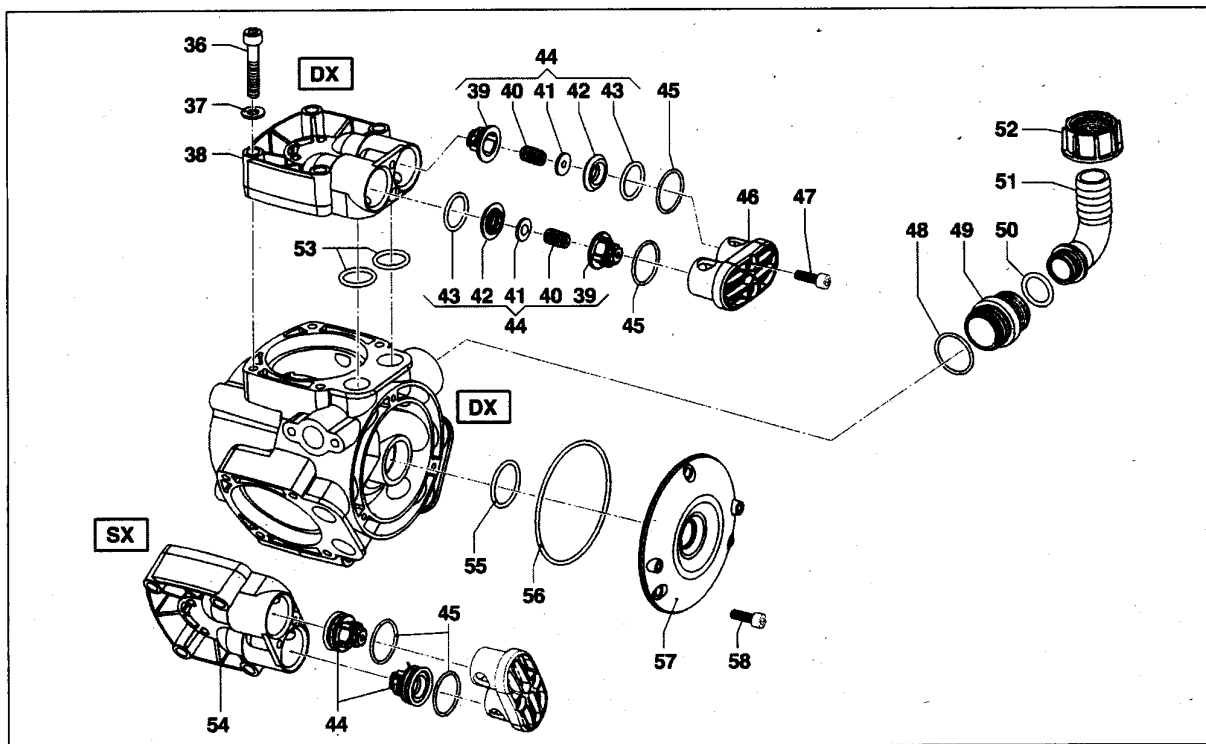
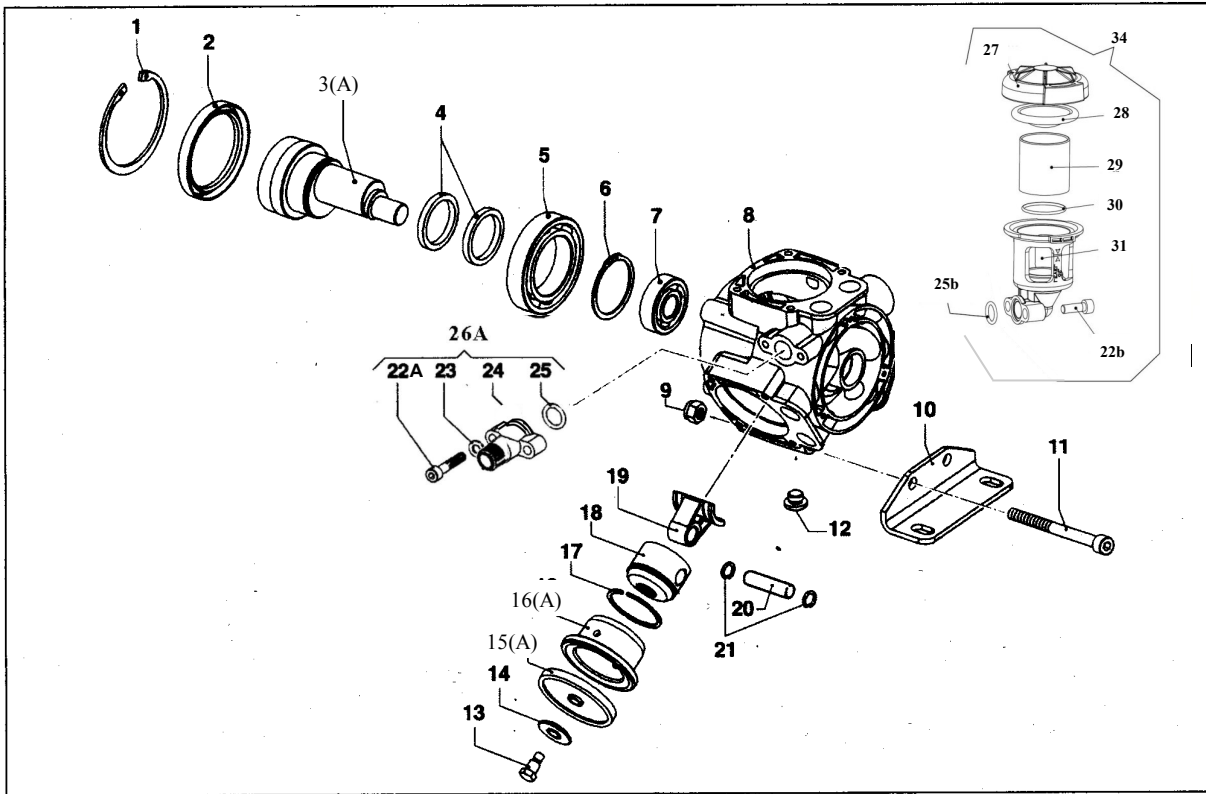

# Gearbox Breakdown

Part #5005/216

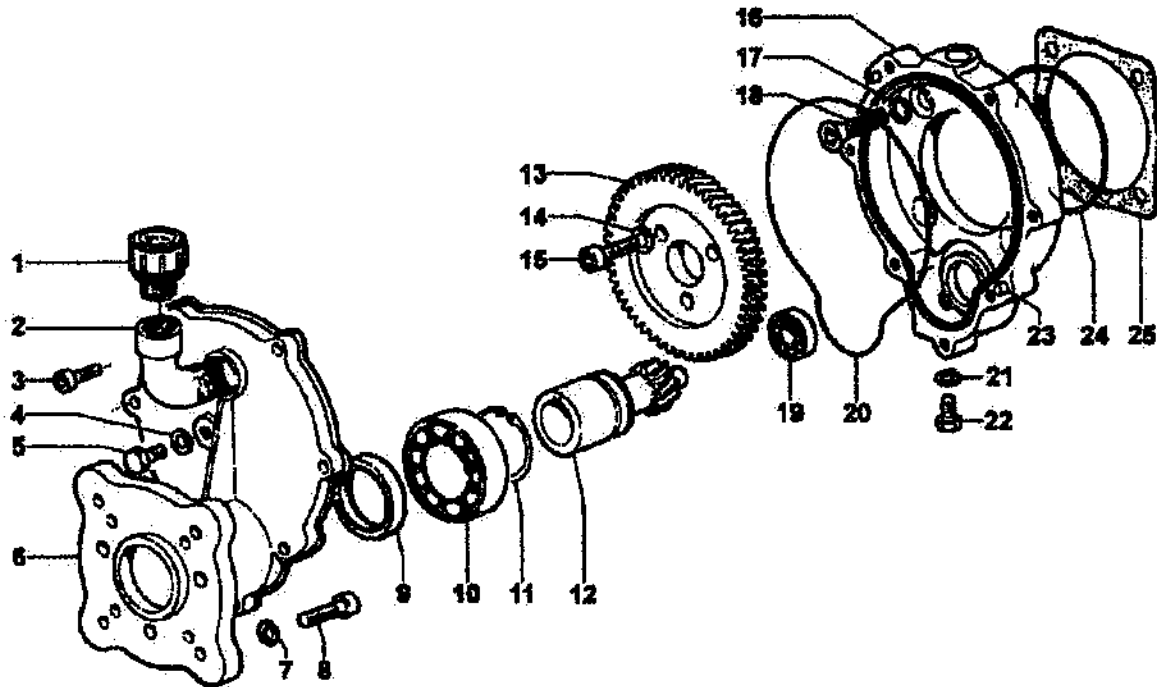

Reference	Part Number	Description	Quantity
1	3200/82	oil vent cap	1
2	1211/23	elbow	1
3	3609/41	screw	7
4	2811/51	washer	1
5	3607/214	level indicator plug	1
6	3002/559	body	1
7	2811/4	washer	4
8	3607/119	screw	4
9	19/109	oil seal	1
10	438/68	bearing	1
11	3019/4	retaining clip	1
12	2402/152	shaft	1
13	409/14	gear	1
14	2811/98	washer	3
15	3609/22	screw	3
16	3001/151	body	1
17	1210/93	o-ring	4
18	3621/6	screw	4
19	438/54	bearing	1
20	1210/89	o-ring	1
21	2811/51	washer	1
22	3607/214	oil plug	1
23	2818/5	stabilizing pin	2
24	1210/50	o-ring	1
25	1201/21	gasket	1

PARTS BREAKDOWN FOR MODEL DP(H)-3B w/COMET  
RICE HYDRO INC.

PUMP PARTS:

REF#	PART NUMBER..	DESCRIPTION..	QTY REQ'D
1	D3-3020-0002	RETAINING CLIP	1
2	D3-0019-0085	SEALING RING	1
3	D3-0001-0444	SHAFT	1
4	D3-0010-0026	CONNECTING ROD RING	2
5	D3-0438-0001	BEARING	1
6	D3-3019-0001	RETAINING CLIP	1
7	D3-0438-0066	BEARING	1
8	D3-0403-0147	CRANKCASE	1
12	D3-3200-0080	OIL PLUG	1
13	D3-3605-0027	BOLT	3
14	D3-0602-0008	DISC	3
15	D3-1800-0020	DIAPHRAGM (in KIT's RH1 & RH2)	3
16	D3-0400-0080	PISTON SLEEVE	3
17	D3-0020-0010	COMPRESSION RING	3
18	D3-2409-0097	PISTON	3
19	D3-0205-0069	CONNECTING ROD (SET OF 3)	1
20	D3-3011-0024	PIN	3
21	D3-3020-0029	RETAINING CLIP	6
22B	D3-3609-0006	ONLY AVAILABLE IN KIT RH5	2
25B	D3-1210-0390	ONLY AVAILABLE IN KIT RH5	1
26A	D3-2803-0662	OUTLET ADAPTER KIT - after S/N 40908	1
26A	D3-2803-0474	OUTLET ADAPTER KIT - before S/N 40908	1
27	D3-0402-0522	ONLY AVAILABLE IN KIT RH5	1
28	D3-1800-0001	ONLY AVAILABLE IN KIT RH5	1
29	D3-1809-0001	ONLY AVAILABLE IN KIT RH5	1
30	D3-1210-0030	ONLY AVAILABLE IN KIT RH5	1
31	D3-0421-0035	ONLY AVAILABLE IN KIT RH5	1
36	D3-3609-0014	SCREW	12
37	D3-2811-0004	WASHER	12
38	D3-3218-0537	HEAD (DX) located top and inlet side Ref #38A spacer included with 3218-0537	2
38A	D3-0601-0436	SPACER	2
44	D3-1220-0052	VALVE ASSY W/ORING (in KIT's RH1, RH3)	6
45	D3-1210-0015	O-RING FOR #46 PLUG (in KIT's RH1, RH3)	6
46	D3-3202-0259	PLUG	3
47	D3-3609-0032	SCREW	6
48	D3-1210-0145	O-RING	1
49	D3-2000-0100	NIPPLE	1
50	D3-1210-0048	O-RING	1
51	D3-2801-0075	HOSE BARB	1
52	D3-1200-0049	WING NUT	1
53	D3-1210-0048	O-RING #38/54 (in KIT's RH1, RH2, RH3)	6
54	D3-3218-0538	HEAD (SX) located pressure side Ref #54A spacer included with 3218-0538	1
54A	D3-0601-0436	SPACER	2
55	D3-1210-0101	O-RING	1
56	D3-1210-0225	O-RING	1
57	D3-1009-0181	FLANGE	1
58	D3-3609-0032	SCREW	3
PUMP OUTLET CONNECTIONS TO PIPING: (REF 26A CONNECTED TO PUMP)			
	EL-BRASS-1/2	1/2" BRASS ELBOW	1
	HOSE-1/2X19	HOSE	1
	D3-2803-0662	OUTLET ADAPTER ASSEMBLY	1



PARTS BREAKDOWN FOR MODEL DP(H)-3B w/COMET  
RICE HYDRO INC.

REF#	PART NUMBER..	DESCRIPTION..	QTY REQ'D
GEAR REDUCTION:			
1	D3-3200-0082	OIL VENT CAP	1
2	D3-1211-0023	ELBOW	1
3	D3-3609-0041	SCREW	7
4	D3-2811-0051	WASHER	1
5	D3-3607-0214	LEVEL INDICATOR PLUG	1
6	D3-3002-0559	BODY	1
7	D3-2811-0004	WASHER	4
8	D3-3607-0119	SCREW	4
9	D3-0019-0109	OIL SEAL	1
10	D3-0438-0068	BEARING	1
11	D3-3019-0004	RETAINING CLIP	1
12	D3-2402-0152	SHAFT	1
13	D3-0409-0014	GEAR	1
14	D3-2811-0098	WASHER	3
15	D3-3609-0022	SCREW	3
16	D3-3001-0151	BODY	1
17	D3-1210-0093	O-RING	4
18	D3-3621-0006	SCREW	4
19	D3-0438-0054	BEARING	1
20	D3-1210-0089	O-RING	1
21	D3-2811-0051	WASHER	1
22	D3-3607-0214	OIL PLUG	1
23	D3-2818-0005	STABILIZING PIN	2
24	<i>** Shown on schematic but not used **</i>		
25	D3-1201-0021	GASKET	1

MISCELLANEOUS PARTS:

NA	GAUGE-600	0-600 PSI LIQUID GAUGE	1
NA	BALLVALVE-1/2	1/2" F X F BALLVALVE	1
NA	CHECKVALVE-1/2F	1/2" F X F 1200PSI INLINE CHECKVALVE	1
NA	CHECKVALVE-1/2M	1/2" M X M INLINE CHECKVALVE	1
NA	SPRAY-6815-700-1/2	1/2" PRESSURE RELIEF VALVE	1
NA	BRIGG-130G32-0022-F1	206 CC FLANGE MOUNT BRIGGS ENGINE	1
NA	HONDA-GX200OUT2-QX2	196 CC FLANGE MOUNT HONDA ENGINE	1
NA	KING-LARGE	SHIPPING BOX FOR DP(H)-3B	1
NA	INLET-HOSE-ASSEMBLY	1" X 9' FOOT CLEAR HOSE W/STRAINER	1
NA	FILTER-SUMP-INLET	1&1/4" 100 MESH INLET STRAINER	1
NA	PUMP-DIA-11/550PSI	REPLACE PUMP W/GEAR REDUCTION	1
NA	D3-5005/216	GEAR REDUCTION	1
NA	DIAPHRAGM-SUCTION	1&1/2" BLACK INLET SUCTION DIAPHRAGM	1
NA	DIAPHRAGM-CLAMP	1&1/2" INLET SUCTION CLAMP	1
NA	LINESTRAINER-1"	1" INLINE STRAINER	1
NA	LABEL-KIT-DP	INSTRUCTION AND CAUTION STICKERS	1
NA	TANK-CAP-ASSY	LID, FLANGE, SCREWS AND CHAIN	1

OUTLET HOSE:

HOSE-1/2X8-RH	8' FOOT OUTLET HOSE - STANDARD	1
<i>*1/2" Male Rigid Fitting &amp; 1/2" Male Swivel Fitting included on 8ft outlet hose</i>		
COUPLERBODY-1/2	QC FEMALE PUMP OUTLET - HOSE	1
COUPLERPLUG-1/2	QC MALE PUMP OUTLET - PIPING	1
HOSE-1/2-2500XFT	SPECIFY LENGTH OF HOSE	
<i>1/2" Male Rigid Fitting &amp; 1/2" Male Swivel Fitting</i>		1

PARTS BREAKDOWN FOR MODEL DP(H)-3B w/COMET  
RICE HYDRO INC.

REF#	PART NUMBER..	DESCRIPTION..	QTY REQ'D
KITS:			
D3-KIT-RH1		DIAPHRAGM REBUILD KIT	
	REF. #15	DIAPHRAGM	QTY 3
	REF. #44	VALVE ASSY W/ORING	QTY 6
	REF. #45	ORING FOR #46 PLUG	QTY 6
	REF. #53	O-RING #38/54 HEAD	QTY 6
		DIAPHRAGM-SUCTION	QTY 1
D3-KIT-RH2		DIAPHRAGM REPAIR KIT	
	REF. #15	DIAPHRAGM	QTY 3
	REF. #53	O-RING #38/54 HEAD	QTY 6
D3-KIT-RH3		VALVE ASSEMBLY & O-RING KIT	
	REF. #44	VALVE ASSY W/ORING	QTY 6
	REF. #45	O-RING FOR #46 PLUG	QTY 6
	REF. #53	O-RING #38/54 HEAD	QTY 6
D3-KIT-RH5		NEW STYLE ALUMINUM SIGHT GLASS KIT	
	REF. #22B	SCREW 30MM	
	REF. #25B	O-RING	
	REF. #27	CAP	
	REF. #28	DIAPHRAGM	
	REF. #29	OIL CUP	
	REF. #30	O-RING	
	REF. #31	OIL CUP	