

MAX FLOW
MAX PRESSURE
RATED PUMP SPEED
POWER REQUIREMENT
LUBRICATION

4.1 GPM / 15.5 L/MIN
2030 PSI / 140 BAR
1750 RPM
6.0 HP ELECTRIC
15.4 OZ UDOR LUBE

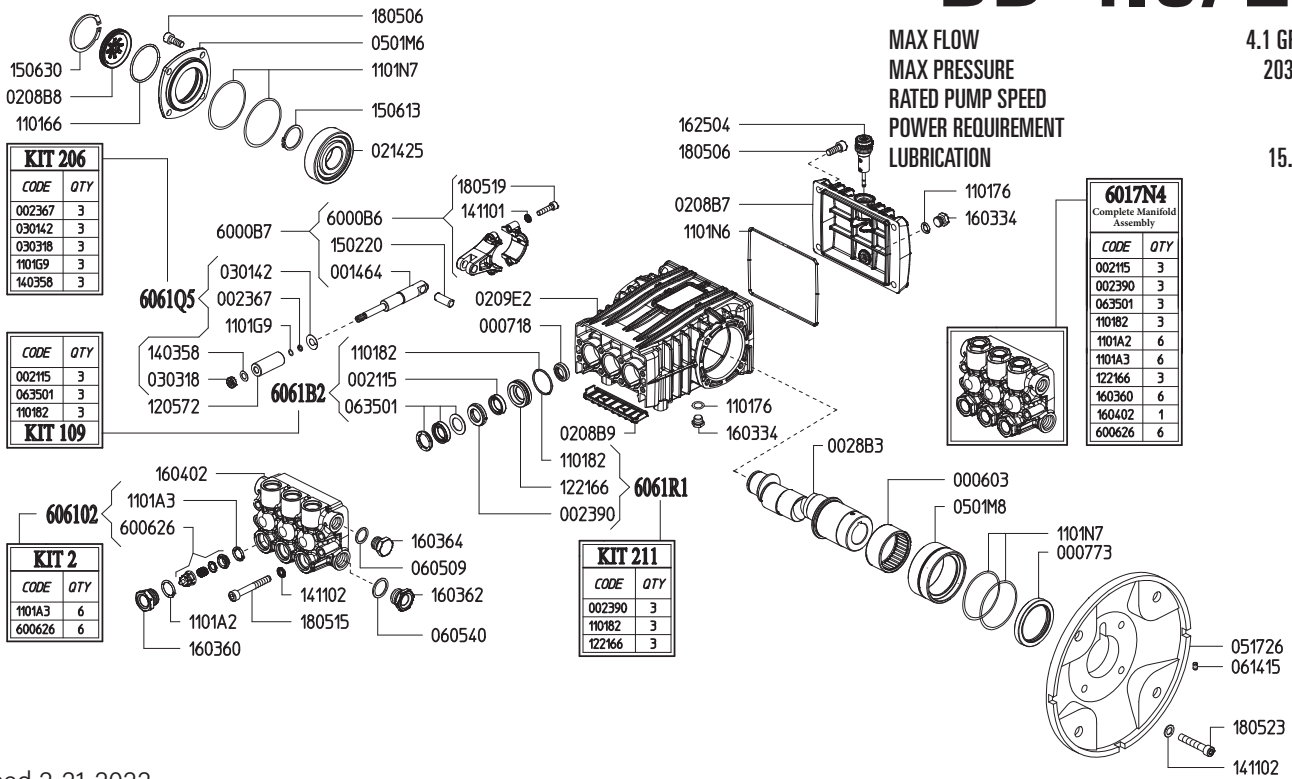

Revised 2-21-2022

Part #	Description	Qty	Part #	Description	Qty
0006.03	BUSHING D50	1	1205.72	CERAAMIC PLUNGER D15 "B/BK"	3
0007.18	OIL SEAL D15X24X5	3	1221.66	PRESSURE RING D15 "B/BK" ^{D E}	3
0007.73	OIL SEAL D50	1	1403.58	WASHER D8 ^C	3
0014.64	PLUNGER GUIDE "B/BK"	3	1411.01	SERATED WASHER D6	6
0021.15	WATER SEAL LP D15X22X5.7 ^{B E}	3	1411.02	SERATED WASHER D8	12
0023.67	RING D5.2X8X1.3 ^C	3	1502.20	PIN D10X27	3
0023.90	UPPER RING D15 "B/BK" ^{D E}	3	1506.13	SNAP RING D30	1
0028.B3	HOLLOW SHAFT "B/BK" D1-1/8"	1	1506.30	SNAP RING D52	1
0208.B7	BACK COVER "B/BK"	1	1603.34	PLUG G1/4	2
0208.B8	OIL SIGHT GLASS	1	1603.60	VALVE PLUG D15/18/20 ^E	+
0208.B9	COVER "B/BK"	1	1603.62	PLUG G1/2	1
0209.E2	CRANKCASE "B-X/BK-X"	1	1603.64	PLUG G3/8	1
0214.25	BALL BEARING D30	1	1604.02	HEAD "BX" ^E	1
0301.42	SLINGER RING ^C	3	1625.04	OIL PLUG G3/8	1
0303.18	NUT M8XH5 ^C	3	1805.03	ALLEN BOLT M8X30	4
0501.M6	BEARING FLANGE "B/BK"	1	1805.06	ALLEN BOLT M8X20	8
0501.M8	BEARING FLANGE "B/BK"	1	1805.15	ALLEN BOLT M8X60	8
0517.27	ENGINE FLANGE "B/BK" HP7/18	1	1805.19	ALLEN BOLT M6X25	6
0605.09	GASKET D17X23X1.5	1	1805.23	ALLEN BOLT M8X40	4
0605.40	GASKET D21.5X27X1.5	1	6000.B6	ROD ASSEMBLY "B/BK"	3
0614.15	SET SCREW M5X8	1	6006.26	VALVE ASSEMBLY WITHOUT O-RING ^{A E}	6
0635.01	HIGH PRESSURE SEAL KIT D15 ^{B E}	3	6017.N4	COMPLETE MANIFOLD ASSEMBLY	1
1101.66	O-RING - OIL SIGHT GLASS	1	6061.02	KIT 2 - VALVE KIT "PK/M/B"	1
1101.76	O-RING - PLUG	2	6061.B2	KIT 109 - WATER SEAL KIT	1
1101.82	O-RING - PRESSURE RING ^{B D E}	3	6061.Q5	KIT 206 - PLUNGER KIT D15/18 "B/BK"	1
1101.A2	O-RING - VALVE PLUG ^E	6	6061.R1	KIT 211 - BRASS RING KIT D15 "B/BK"	1
1101.A3	O-RING - VALVE ^{A E}	6			
1101.G9	O-RING - PLUNGER ROD ^C	3			
1101.N6	O-RING - BACK COVER	1			
1101.N7	O-RING - BEARING FLANGE	4			

A Parts in 6061.02 (Kit 2).
B Parts in 6061.B2 (Kit 109).
C Parts in 6061.Q5 (Kit 206).
D Parts in 6061.R1 (Kit 211).
E Parts in 6017.N4 (Complete Manifold Assembly).

WEIGHT
LUBRICATION

23 LBS
15.4 OZ UDOR LUBE

*Dimensional Drawings are
Shown in Millimeters.
To Convert to Inches,
Multiply Dimension x 0.03937*

B SERIES PUMPS - 1-1/8" HOLLOW SHAFT w/ 182/184 FLANGE

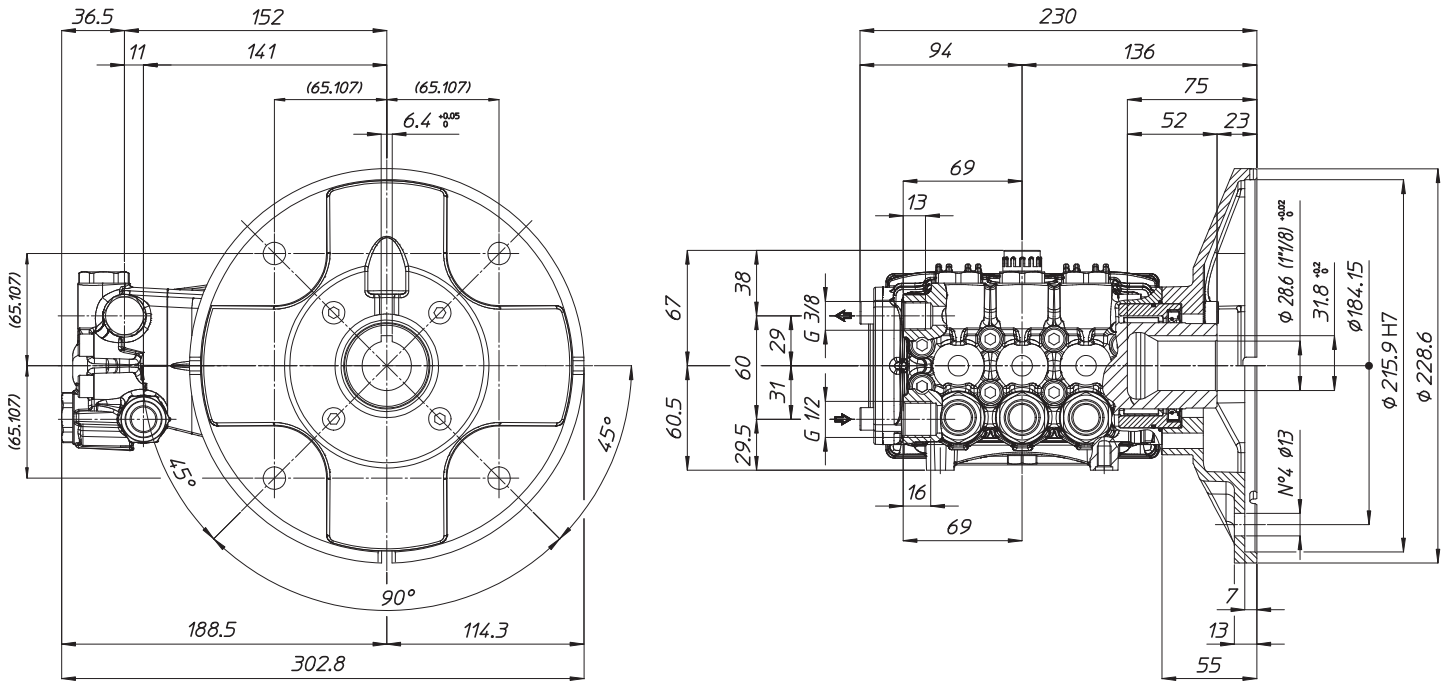

TORQUE SPECS

Ref.	Description	Ft./lb.	Nm	Loctite®
1	Head Bolts	19	25	-
2	Valve Caps	75	100	243
3	Inlet Cap	75	100	243
4	Outlet Cap	60	80	243
5	Bearing Flange Bolts	19	25	-
6	Rear Cover Bolts	19	25	-
7	Connecting Rod Bolts	9	11	243
8	Plunger Bolts	11	15	270
9	Valve Cover Bolts	-	-	-
10	Oil Drain Plug	19	25	-

