



**MODEL DPH6, DPH-8 & DPH-56/250 INSTALLATION INSTRUCTIONS
RI-10 (WHEEL & HANDLE) KIT & 6/8B-PRESSURED TANK**

**FOR WARRANTY REGISTRATION CALL: 1-800-245-4777
RICEHYDRO.COM**



RECOMMENDED TOOLS

1/2" WRENCH

1/2" SOCKET/RACHET

HAMMER

FLAT HEAD SCREWDRIVER

*NO TANK AVAILABLE ON MODEL DPH-56/250

PARTS LIST

(2) 10" NO-FLAT TIRES



(1) HANDLE



(1) 5/8" AXLE



(2) 5/8" FLAT WASHERS



(2) 5/8" PUSH NUTS



(2) 5/16" X 1 & 3/4" BOLTS



(1) FOOT ASSEMBLY



(4) 5/16" X 18 LOCKNUTS



(8) 5/16" FLAT WASHERS



(1) 6/8-PRESSURED TANK



(1) 1 & 1/2" ELBOW



(1) 20" 1 & 1/2" HOSE



(2) 5/16" X 1" BOLTS



(2) HOSECLAMP



ASSEMBLY INSTRUCTIONS

IMPORTANT. 1 & 1/2" ELBOW MUST BE INSTALLED ON INLET PIPING BEFORE WHEELS & AXLE

Step 1. CONNECTING 1 & 1/2" ELBOW TO INLET PIPING

Connect 1 & 1/2" ELBOW to the inlet piping. IMPORTANT: inlet elbow must be installed prior to wheel and axle.



***NO TANK AVAILABLE ON MODEL DPH-56/250
MOVE ON TO NEXT STEP**

Step 3. INSTALLING (1) 5/8" AXLE & (2) 10" NO-FLAT TIRES

Directly under the engine side, slide 5/8" AXLE through the existing holes that were created in STEP 2, at the bottom of the base. Next, slide on 5/8" WASHER, and 10" WHEEL. Secure TIRE by hammering on the PUSH NUTS as shown below. Repeat for other side.



Step 5. INSTALLING (1) 8B PRESSURED TANK & (1) HANDLE TO PUMP FRAME

First, align pre-drilled holes on TANK bracket with PUMP frame holes. Next, place HANDLE on the inside of the pump frame using existing holes as shown below. From STEP 1, use BOLTS, WASHERS, & LOCKNUTS with the rest from the package. Insert a BOLT, 2 WASHERS, & 1 LOCKNUT in each of the 4 existing holes to secure HANDLE & TANK. Use Wrench/Ratchet to tighten.

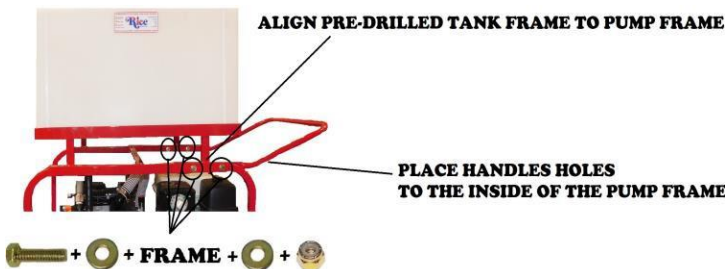

Step 2. REMOVE 5/16" X 1 & 3/4" BOLTS, WASHERS, & LOCKNUTS

As shown below, remove from each side 5/16" X 1 & 3/4" BOLTS, WASHERS, & LOCKNUTS and save for STEP 4. Use Wrench/Ratchet to loosen bolts.

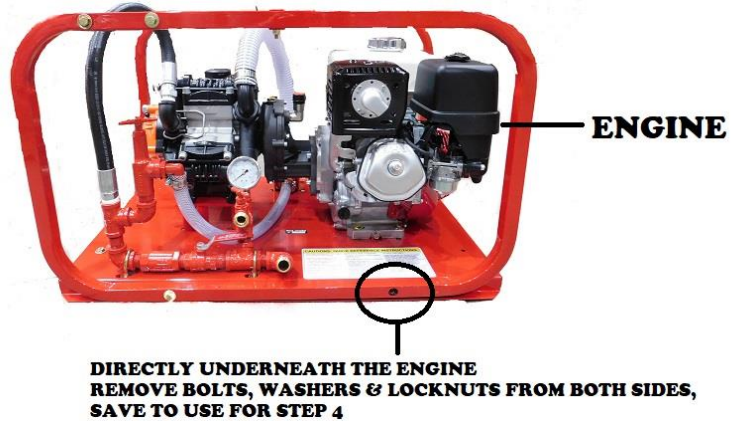

Step 4. INSTALLING (1) REST FOOT

Place REST FOOT under pump side of base using existing holes as shown below. Insert BOLT, 2 WASHERS, & 1 LOCKNUT in each of the existing holes. Use Wrench/Ratchet to tighten.

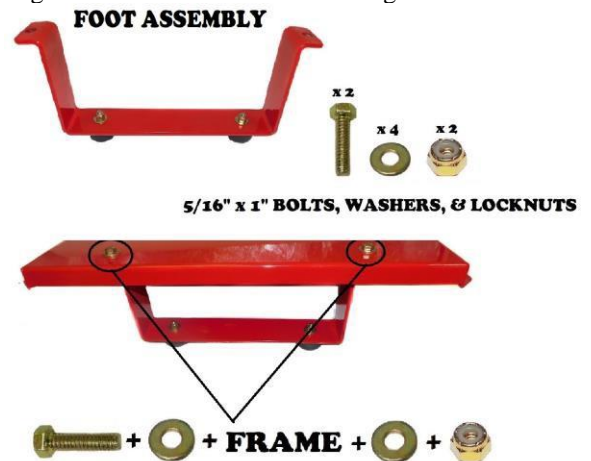

REMINDER, IF NO TANK IGNORE THIS STEP

Step 6. CONNECT TANK OUTLET TO PUMP INLET

First, join the 20" HOSE with 1 & 1/2" Barb already on the bottom of the tank and tighten with HOSECLAMP. Second, slide HOSE over ELBOW & use HOSECLAMP to tighten.

